

HUSKY FIBERGLASS

Cable Tray

Technical Information	Pgs. 2—6
Installation Guide	Pg. 7
Corrosion Guide	Pgs. 8—11
6" Husky Fiberglass Tray	Pgs. 12—21
4" Husky Fiberglass Tray	Pgs. 22—30
3" Husky Fiberglass Tray	Pgs. 31—36
Channel Husky Fiberglass Tray	Pgs. 37—41
Specifications	Pg. 42
Fittings & Accessories	Pgs. 43—46
Strut Section	Pgs. 47—55



MP HUSKY CABLE TRAY

For more than 30 years, MPHusky's Fiberglass Cable Tray systems have been tested and proven in the harsh environment of the offshore oil and gas industry. Our tray has stood up to the test of being exposed to the corrosive conditions inherent in petroleum products, plus the daily punishment of exposure to wind, weather and salt water. MPHusky Fiberglass Cable Tray gives you the load capacity of steel, plus the inherent characteristics afforded by our Pultrusion Technology: non-conductive, non-magnetic and corrosion-resistant. Although light in weight, the strength to weight ratio surpasses that of equivalent steel products. Husky Fiberglass Cable Tray will not rust, nor does it ever require painting. It is available in both polyester and vinylester resin systems, manufactured to meet ASTM E-84, Class 1 Flame Rating and self-extinguishing requirements of ASTM D-635. Husky's Fiberglass Cable Tray comes in gray or blue (polyester resin) and beige (vinylester resin) but is available in custom colors upon request.



Load Data

Effect of Temperature

Strength properties of reinforced plastics are reduced when continuously exposed to elevated temperatures. Working loads shall be reduced based on the following:

Temperature in Degrees F	Approximate Percent of Strength
75	100
100	90
125	78
150	68
175	60
200	52

NEMA Standard 8-10-1986. If unusual temperature conditions exist, please consult the manufacturer.

Typical Properties of Pultruded Components

MPHusky's Fiberglass Cable Tray systems are manufactured from glass fiber-reinforced plastic shapes that meet ASTM E-84, Class 1 Flame Rating and self-extinguishing requirements of ASTM D-635. A surface veil is applied during pultrusion to insure a resin-rich surface and ultraviolet resistance.

Properties	Test Method	Unit / Value	3" & 4" Cable Tray, Cable Channel		6" Cable Tray	
			Longitudinal	Transverse	Longitudinal	Transverse
Tensile Strength	ASTM D638	Psi	30,000	7,000	40,000	4,500
Tensile Modulus	ASTM D638	Psi x 10 ⁶	2.5	.8	3.2	.6
Flexural Strength	ASTM D790	psi	30,000	10,000	40,000	10,000
Flexural Modulus	ASTM D790	Psi x 10 ⁶	1.6	.8	2.1	.8
Izod Impact	ASTM D256	ft-lbs/in	28	4	28	4
Compressive Strength	ASTM D695	Psi	30,000	15,000	40,000	10,000
Compressive Modulus	ASTM D695	Psi x 10 ⁶	2.5	1.0	3.2	.7
Barcol Hardness	ASTM D2583	--	45	45	45	45
Shear Strength	ASTM D732	Psi	5,500	5,500	5,500	5,500
Density	ASTM D1505	Lbs/in ³	.058-.062	--	.072-.076	--
Coefficient of Thermal Expansion	ASTM D696	In/in/°F	5.0x10 ⁻⁶	--	5.0x10 ⁻⁶	--
Water Absorption	ASTM D570	Max %	0.5	--	0.5	--
Dielectric Strength	ASTM D149	v/mil	200	--	200	--
Flammability Classification	UL94	(vpm)	--	--	--	--
Flame Spread	ASTM E-84	VO 20 Max	--	--	--	--
Flame Resistance (FTMS 406-2023) ignition / burn, seconds					75 / 75	
Intermittent Flame Test rating (HLT-15)					100	
Flammability Test (ASTM D635) Ignition Burning Time					None 0 sec.	

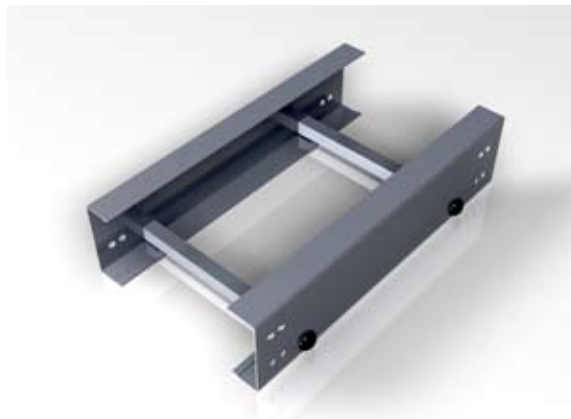

FIBERGLASS

Cable Tray Thermal Contraction and Expansion

It is important that thermal contraction and expansion be considered when installing cable tray systems. The length of the straight cable tray runs and the temperature differential govern the number of expansion splice plates required (see Table 1). The cable tray should be anchored at the support nearest to its midpoint between the expansion splice plates and secured by expansion guides at all other support locations (See Figure 1). The cable tray should be permitted longitudinal movement in both directions from that fixed point.

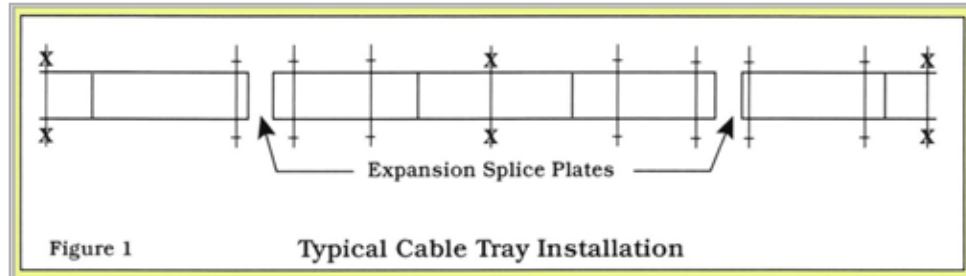

Table 1

Expansion or Contraction for Various Temperature Differences

Temperature Differential °F	Cable Tray Length for 1" Expansion	Each Tray Length for Expansion Connector*
25	667 Feet	417 Feet
50	333 Feet	208 Feet
75	222 Feet	139 Feet
100	167 Feet	104 Feet
125	133 Feet	83 Feet
150	111 Feet	69 Feet
175	95 Feet	59 Feet

Note for gap set and hold down/guide location, see installation instruction above.
*1" slotted holes in each expansion connector allow 5/8" total expansion or contraction.

Accurate gap setting at the time of installation is necessary for the proper operation of the expansion splice plates. The following procedure should assist the installer in determining the correct gap (see Figure 2):

1. Plot the highest expected tray temperature on the maximum temperature line
2. Plot the lowest expected tray temperature on the minimum temperature line
3. Draw a line between the maximum and minimum points
4. Plot the tray temperature at the time of installation to determine the gap setting

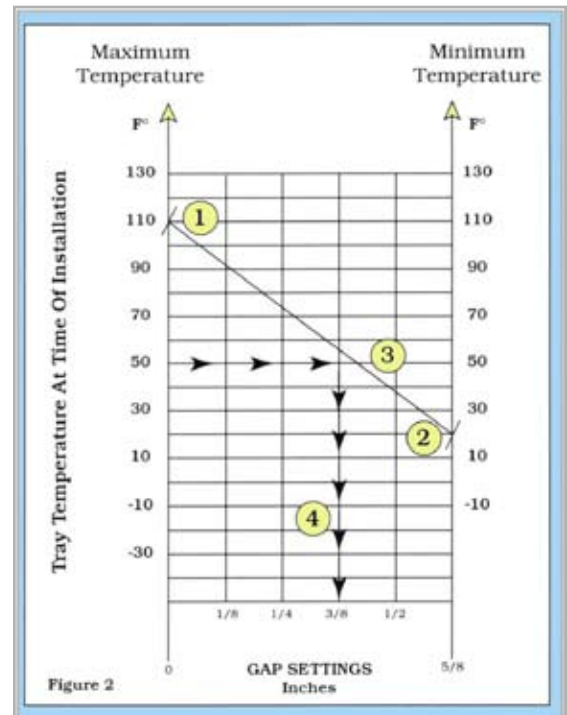

Cable Tray Installation Guide

Installation of MPHusky Fiberglass Cable Tray should be made in accordance with the standards set by NEMA Publication VE-2 latest edition and National Electrical Code, Article 392.

- ◆ Always observe common safety practices when assembling tray and fittings. Installations generally require some field cutting. Dust created during fabrication presents no serious health hazard, but skin irritation may be experienced by some workers.
- ◆ Operators of saws and drills should wear masks, long sleeve shirts, or coveralls.
- ◆ Fabrication with Husky Fiberglass is relatively easy and comparable to working with wood. Ordinary hand tools may be used in most cases.
- ◆ Avoid excessive pressure when sawing or drilling. Too much force can rapidly dull tools and also produce excessive heat which softens the bonding resin in the Husky Fiberglass, resulting in a ragged edge rather than a clean-cut edge.
- ◆ Field cutting is simple and can be accomplished with a circular power saw with an abrasive cut-off wheel (masonry type) or hack saw (24 to 32 teeth per inch).
- ◆ Drill Husky Fiberglass as you would drill hard wood. Standard twist drills are more than adequate.
- ◆ Any surface that has been drilled, cut, sanded or otherwise broken, **must be sealed** with a compatible resin.
- ◆ Carbide tipped saw blades and drill bits are recommended when cutting large quantities.
- ◆ Support the Husky Fiberglass material firmly during cutting operations to keep material from shifting, which may cause chipping at the cut edge.
- ◆ Each tray section length should be equal to or greater than the support span.
- ◆ When possible, the splice should be located at quarter span.
- ◆ Fittings should be supported as per NEMA VE-2.

CHEMICAL ENVIROMENT	POLYESTER		VINYLESTER	
	Max Wt. %	Max Oper. Temp *F	Max Wt. %	Max Temp. *F
Acetic Acid	10	190	10	210
Acetic Acid	50	125	50	180
Acetone	N/R	N/R	100	75
Aluminum Chloride	SAT	170	SAT	200
Aluminum Hydroxide	SAT	160	SAT	170
Aluminum Nitrate	SAT	150	SAT	170
Aluminum Sulfate	SAT	180	SAT	200
Ammonium Chloride	SAT	170	SAT	190
Ammonium Hydroxide	1	100	10	150
Ammonium Hydroxide	28	N/R	28	100
Ammonium Carbonate	N/R	N/R	SAT	150
Ammonium Bicarbonate	15	125	SAT	130
Ammonium Nitrate	SAT	160	SAT	190
Ammonium Per sulfate	SAT	N/R	SAT	150
Ammonium Sulfate	SAT	170	SAT	200
Amyl Alcohol	ALL	N/R	ALL	90
Amyl Alcohol Vapor	—	140	—	120
Benzene	N/R	N/R	100	140
Benzene Sulfonic Acid	25	110	SAT	200
Benzoic Acid	SAT	150	SAT	200
Benzoyl Alcohol	100	N/R	100	N/R
Borax	SAT	170	SAT	200
Calcium Carbonate	SAT	170	SAT	200
Calcium Chloride	SAT	170	SAT	200
Calcium Hydroxide	25	70	25	165
Calcium Nitrate	SAT	180	SAT	200
Calcium Sulfate	SAT	180	SAT	200
Carbon Disulfide	N/R	N/R	N/R	N/R
Carbonic Acid	SAT	130	SAT	180
Carbon Dioxide Gas	—	200	—	200
Carbon Monoxide Gas	—	200	—	200
Carbon Tetrachloride	N/R	N/R	100	75
Chloride, Dry Gas	—	140	—	170
Chloride, Wet Gas	—	N/R	—	180
Chlorine Water	SAT	80	SAT	180

FIBERGLASS

CHEMICAL ENVIROMENT	POLYESTER		VINYLESTER	
	Max Wt. %	Max Oper. Temp *F	Max Wt. %	Max Temp. *F
Chromic Acid	5	70	10	120
Citric Acid	SAT	170	SAT	200
Copper Chloride	SAT	170	SAT	200
Copper Cyanide	SAT	170	SAT	200
Copper Nitrate	SAT	170	SAT	200
Crude Oil, Sour	100	170	100	200
Cyclohexane	N/R	N/R	N/R	N/R
Cyclohexane, Vapor	ALL	100	ALL	130
Diesel Fuel	100	160	100	180
Diethyl Ether	N/R	N/R	N/R	N/R
Dimethly Phthalate	N/R	N/R	N/R	N/R
Ethanol	50	75	50	90
Ethyl Acetate	N/R	N/R	N/R	N/R
Ethylene Chloride	N/R	N/R	N/R	N/R
Ethylene Glycol	100	90	100	200
Fatty Acids	SAT	180	SAT	200
Ferric Chloride	SAT	170	SAT	200
Ferric nitrate	SAT	170	SAT	200
Ferric Sulfate	SAT	170	SAT	200
Ferrous Chloride	SAT	170	SAT	200
Fluoboric Acid	N/R	N/R	SAT	165
Fluosilicic Acid	N/R	N/R	SAT	70
Formaldehyde	50	75	50	100
Formic Acid	N/R	N/R	50	100
Gasoline	100	80	100	150
Glucose	100	170	100	200
Glycerin	100	150	100	200
Heptanes	100	110	100	200
Hexane	100	90	100	130
Hydrotropic Acid	50	120	50	120
Hydrochloric Acid	10	150	10	200
Hydrochloric Acid	20	140	20	190
Hydrochloric Acid	37	75	37	95
Hydrochloric Acid	N/R	N/R	15	80
Hydrogen Bromide, Dry	100	190	100	200

FIBERGLASS

CHEMICAL ENVIROMENT	POLYESTER		VINYLESTER	
	Max Wt. %	Max Oper. Temp *F	Max Wt. %	Max Temp. *F
Hydrogen Bromide, Wet	100	75	100	130
Hydrogen Chloride	—	120	—	200
Hydrogen Peroxide	5	100	30	100
Hydrogen Sulfide, Dry	100	170	100	210
Hydrogen Sulfide, Wet	100	170	100	210
Hypochlorus Acid	20	80	20	150
Isopropyl Alcohol	N/R	N/R	15	80
Kerosene	100	140	100	180
Lactic Acid	SAT	170	SAT	200
Lead Acetate	SAT	170	SAT	200
Lead Chloride	SAT	140	SAT	200
Lead Nitrate	SAT	—	SAT	200
Linseed Oil	100	150	100	190
Lithium Chloride	SAT	150	SAT	190
Magnesium Carbonate	SAT	140	SAT	170
Magnesium Chloride	SAT	170	SAT	200
Magnesium Hydroxide	SAT	150	SAT	190
Magnesium Nitrate	SAT	140	SAT	180
Magnesium Sulfate	SAT	170	SAT	190
Mercuric Chloride	SAT	150	SAT	190
Mercurous Chloride	SAT	140	SAT	180
Methyl Ethyl Ketene	N/R	N/R	N/R	N/R
Mineral Oils	100	170	100	200
Monochlorobenze	N/R	N/R	N/R	N/R
Naphtha	100	140	100	170
Nickel Chloride	SAT	170	SAT	200
Nickel Nitrate	SAT	170	SAT	200
Nickel Sulfate	SAT	170	SAT	200
Nitric Acid	5	140	5	150
Nitric Acid	20	70	20	100
Oleic Acid	100	170	100	190
Oxalic Acid	ALL	75	ALL	120
Paper Mill Liquors	—	100	—	120
Perchlorethylene	100	N/R	100	N/R
Perchloric Acid	N/R	N/R	10	150
Perchloric Acid	N/R	N/R	30	80
Phosporic Acid	10	160	10	200
Phosporic Acid	100	120	100	200
Potassium Aluminum Sulfate	SAT	170	SAT	200
Potassium Bicarbonate	50	80	50	140
Potassium Carbonate	10	N/R	10	120
Potassium Chloride	SAT	170	SAT	200

FIBERGLASS

CHEMICAL ENVIROMENT	POLYESTER		VINYLESTER	
	Max Wt. %	Max Oper. Temp *F	Max Wt. %	Max Temp. *F
Potassium Hydroxide	N/R	N/R	25	150
Potassium Nitrate	SAT	170	SAT	200
Potassium Permanganate	100	80	100	210
Potassium Sulfate	SAT	170	SAT	200
Propylene Glycol	ALL	170	ALL	200
Phthalic Acid	—	—	SAT	200
Sodium Acetate	SAT	160	SAT	200
Sodium Bicarbonate	SAT	160	SAT	175
Sodium Bisulfate	ALL	170	ALL	200
Sodium Bromide	ALL	170	ALL	200
Sodium Carbonate	10	80	35	160
Sodium Chloride	SAT	170	SAT	200
Sodium Cyanide	SAT	170	SAT	200
Sodium Hydroxide	N/R	N/R	50	150
Sodium Hydroxide	N/R	N/R	25	80
Sodium Hypochloride	N/R	N/R	10	150
Sodium Monophosphate	SAT	170	SAT	200
Sodium Nitrate	SAT	170	SAT	200
Sodium Sulfate	SAT	170	SAT	200
Sodium Thiosulfate	ALL	100	ALL	120
Stannic Chloride	SAT	160	SAT	190
Styrene	N/R	N/R	N/R	N/R
Sulfated Detergent	0/50	170	0/50	200
Sulfur Dioxide	100	80	100	200
Sulfur Trioxide	100	80	100	200
Sulfuric Acid	93	N/R	93	N/R
Sulfuric Acid	50	N/R	50	180
Sulfuric Acid	25	75	25	190
Sulfurous Acid	SAT	80	N/R	N/R
Tartaric Acid	SAT	170	SAT	200
Tetrachloroethylene	N/R	N/R	FUM	75
Toluene	N/R	N/R	N/R	N/R
Trisodium Phosphate	N/R	N/R	SAT	175
Urea	SAT	130	SAT	140
Vinegar	100	170	100	200
Water, Distilled	100	170	100	190
Water, Tap	100	170	100	190
Water, Sea	SAT	170	SAT	190
Xylene	N/R	N/R	N/R	N/R
Zinc Chloride	SAT	170	SAT	200
Zinc Nitrate	SAT	170	SAT	200
Zinc Sulfate	SAT	170	SAT	200

FIBERGLASS

Numbering System

6BP-9-24-120				
6B	P-	9-	24-	240
Series	Material	Rung Spacing	Width	Length
6" (6B, 6C, H6C) Based on NEMA classification—see next page for details	P=Polyester Resin V=Vinylester Resin	6" 9" 12" 18"	6" 9" 12" 18" 24" 30" 36"	120 (10ft.) 240 (20ft.)

How to Order Husky Fiberglass Cable Tray:

1. Select the correct MPHusky Series Cable Tray using the Load Data for straight sections shown in the appropriate tabbed section for 6", 4" and 3" Cable Tray. **Please refer to the chart on Page 13 to choose part number for NEMA Classification.** (Example: 6B-P-09-24-240 would be for NEMA 20B tray).
2. Select the resin required. Refer to the Corrosion Guide on pages 8-11 of the Technical Data Section for the effect of environmental conditions on the desired material. This section also contains the temperature range for our tray.
3. The tray prefix is completed by inserting the rung spacing.
4. The fourth box contains the straight section width in inches.
5. The fifth box contains the straight section length in inches.

Please note: One pair of splice plates with hardware is included.



To obtain deflection at any span length for lighter loads than listed, multiply the load by the K factor. When trays are used in continuous spans, the deflection of the tray is reduced by as much as 50%.

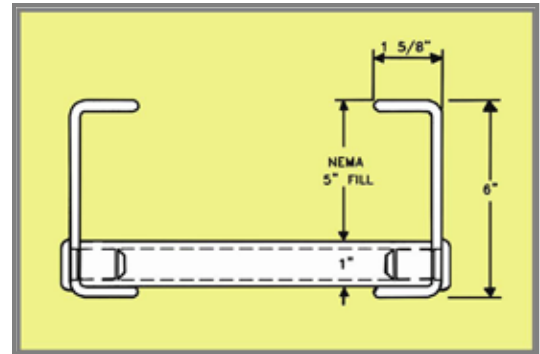

Husky Series 6B / NEMA 20B					Safety Factor 1.5
Span (Ft.)	12	14	16	18	20
Design Load Lbs./Ft.	254	186	143	113	91
Deflection	1.6	2.2	2.8	3.6	4.4
K Factor	0.006	0.012	0.020	0.032	0.048
<i>*Tested per NEMA FG-1, 12" rung spacing</i>					

Husky Series 6C / NEMA 20C					Safety Factor 1.5
Span (Ft.)	12	14	16	18	20
Design Load Lbs./Ft.	356	262	200	158	128
Deflection	1.6	2.2	2.9	3.7	4.6
K Factor	0.004	0.008	0.015	0.023	0.136
<i>*Tested per NEMA FG-1, 12" rung spacing</i>					

Husky Series H6C / NEMA 20C					Safety Factor 1.5
Span (Ft.)	12	14	16	18	20
Design Load Lbs./Ft.	386	283	217	171	139
Deflection	1.8	2.4	3.2	4.0	5.0
K Factor	0.005	0.008	0.015	0.023	0.036

Husky Series H6C/ NEMA 20C					Safety Factor 2.0
Span (Ft.)	12	14	16	18	20
Design Load Lbs./Ft.	289	212	163	129	104
Deflection	1.3	1.8	2.4	3.0	3.7
K Factor	0.004	0.008	0.015	0.023	0.036
<i>Loading—NEMA 20C *tested per NEMA FG-1, 12" rung spacing</i>					

FIBERGLASS

90° Horizontal Bend Dimensions.

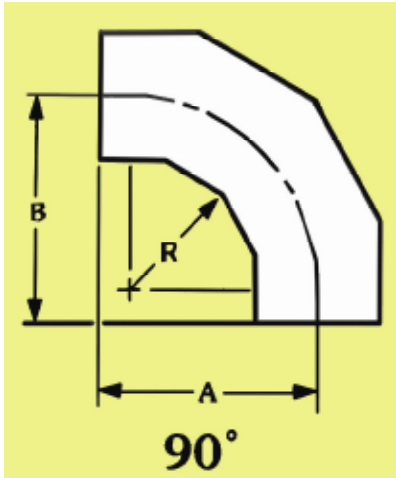

-R- Bend Radius (in.)	Tray Width (in.)	Catalog Number	A Inches	B Inches
12	6	(Prefix)-06-90HB12	20-3/8	20-3/8
	9	(Prefix)-09-90HB12	21-7/8	21-7/8
	12	(Prefix)-12-90HB12	22-3/8	22-3/8
	18	(Prefix)-18-90HB12	26-3/8	26-3/8
	24	(Prefix)-24-90HB12	29-3/8	29-3/8
	30	(Prefix)-30-90HB12	32-3/8	32-3/8
24	6	(Prefix)-06-90HB24	34-1/4	34-1/4
	9	(Prefix)-09-90HB24	35-3/4	35-3/4
	12	(Prefix)-12-90HB24	37-1/4	37-1/4
	18	(Prefix)-18-90HB24	40-1/4	40-1/4
	24	(Prefix)-24-90HB24	43-1/4	43-1/4
	30	(Prefix)-30-90HB24	46-1/4	46-1/4
36	6	(Prefix)-06-90HB36	46-1/4	46-1/4
	9	(Prefix)-09-90HB36	47-3/4	47-3/4
	12	(Prefix)-12-90HB36	49-1/4	49-1/4
	18	(Prefix)-18-90HB36	52-1/4	52-1/4
	24	(Prefix)-24-90HB36	55-1/4	55-1/4
	30	(Prefix)-30-90HB36	58-1/4	58-1/4
36	(Prefix)-36-90HB36	61-1/4	61-1/4	

45° Horizontal Bend Dimensions

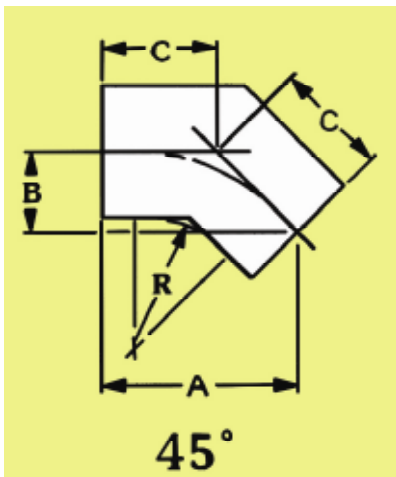

-R- Bend Radius (in.)	Tray Width (in.)	Catalog Number	A Inches	B Inches	C Inches
12	6	Prefix)-06-45HB12	22-13/16	9-7/16	13-3/8
	9	(Prefix)-09-45HB12	23-7/8	9-7/8	14
	12	(Prefix)-12-45HB12	24-7/8	10-5/16	14-5/8
	18	(Prefix)-18-45HB12	27-1/16	11-3/16	15-7/8
	24	(Prefix)-24-45HB12	29-3/16	12-1/16	17-1/8
	30	(Prefix)-30-45HB12	31-5/16	13	18-3/8
24	6	(Prefix)-06-45HB24	24-3/16	10-1/16	14-3/16
	9	(Prefix)-09-45HB24	25-1/4	10-1/2	14-13/16
	12	(Prefix)-12-45HB24	26-5/16	10-15/16	15-7/16
	18	(Prefix)-18-45HB24	28-7/16	11-13/16	16-11/16
	24	(Prefix)-24-45HB24	30-9/16	12-11/16	17-15/16
	30	(Prefix)-30-45HB24	32-11/16	13-9/16	19-3/16
36	6	Prefix)-06-45HB36	32-5/8	13-1/2	19-1/8
	9	(Prefix)-09-45HB36	33-11/16	13-15/16	19-3/4
	12	(Prefix)-12-45HB36	34-3/4	14-3/8	20-3/8
	18	(Prefix)-18-45HB36	36-7/8	15-1/4	21-5/8
	24	(Prefix)-24-45HB36	39	16-3/16	22-7/8
	30	(Prefix)-30-45HB36	41-1/8	17-1/16	24-1/8
36	(Prefix)-36-45HB36	43-1/4	17-15/16	25-5/16	

FIBERGLASS

90° Vertical Bend

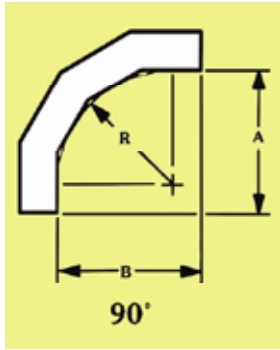

Vertical Outside Bend

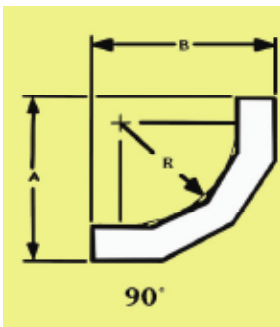

Vertical Inside Bend

-R-Bend Radius (in.)	Tray Width (in.)	Catalog Number	Vertical Outside Bend		Vertical Inside Bend	
			A In.	B In.	A In.	B In.
12	6	(Prefix)-06-90(*)12	20-5/8	20-5/8	27-1/16	27-1/16
	9	(Prefix)-09-90(*)12				
	12	(Prefix)-12-90(*)12				
	18	(Prefix)-18-90(*)12				
	24	(Prefix)-24-90(*)12				
	30	(Prefix)-30-90(*)12				
24	6	(Prefix)-06-90(*)24	31-1/4	31-1/4	37-1/4	37-1/4
	9	(Prefix)-09-90(*)24				
	12	(Prefix)-12-90(*)24				
	18	(Prefix)-18-90(*)24				
	24	(Prefix)-24-90(*)24				
	30	(Prefix)-30-90(*)24				
36	6	(Prefix)-06-90(*)36	43	43	49-1/2	49-1/2
	9	(Prefix)-09-90(*)36				
	12	(Prefix)-12-90(*)36				
	18	(Prefix)-18-90(*)36				
	24	(Prefix)-24-90(*)36				
	30	(Prefix)-30-90(*)36				
36	(Prefix)-36-90(*)36					

45° Vertical Bend

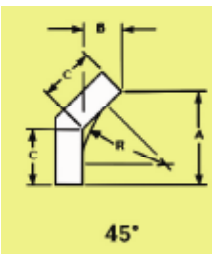

Vertical Outside Bend

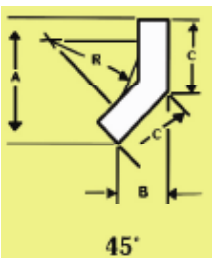

Vertical Inside Bend

-R-Bend Radius (in.)	Tray Width (in.)	Catalog Number	Vertical Outside Bend			Vertical Inside Bend		
			A In.	B In.	C In.	A In.	B In.	C In.
12	6	(Prefix)-06-45(*)12	20-1/2	8-1/2	12	24-3/4	10-1/4	14-1/2
	9	(Prefix)-09-45(*)12						
	12	(Prefix)-12-45(*)12						
	18	(Prefix)-18-45(*)12						
	24	(Prefix)-24-45(*)12						
	30	(Prefix)-30-45(*)12						
24	6	(Prefix)-06-45(*)24	22-1/4	9-1/8	12-15/16	26-5/16	10-15/16	15-7/16
	9	(Prefix)-09-45(*)24						
	12	(Prefix)-12-45(*)24						
	18	(Prefix)-18-45(*)24						
	24	(Prefix)-24-45(*)24						
	30	(Prefix)-30-45(*)24						
36	6	(Prefix)-06-45(*)36	30-9/16	12-11/16	17-15/16	34-13/16	14-7/16	20-3/8
	9	(Prefix)-09-45(*)36						
	12	(Prefix)-12-45(*)36						
	18	(Prefix)-18-45(*)36						
	24	(Prefix)-24-45(*)36						
	30	(Prefix)-30-45(*)36						
36	(Prefix)-36-45(*)36							

Note: Dimensions are for reference only, when critical, contact factory. Consult factory for availability of molded fittings. * Insert VO for vertical outside bend or VI for vertical inside bend.

6" Horizontal Tee & Cross

Horizontal Tee

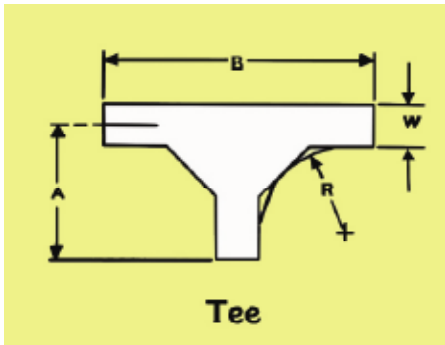

-R- Bend Radius (in.)	Tray Width (in.)	Catalog Number	A Inches	B Inches
12	6	(Prefix)-06-HT12	19-1/4	38
	9	(Prefix)-09-HT12	20-3/4	41
	12	(Prefix)-12-HT12	22-1/4	44
	18	(Prefix)-18-HT12	25-1/4	50
	24	(Prefix)-24-HT12	28-1/4	56
	30	(Prefix)-30-HT12	31-1/4	62
24	36	(Prefix)-36-HT12	34-1/4	68
	6	(Prefix)-06-HT24	34-1/4	68-1/2
	9	(Prefix)-09-HT24	35-3/4	71-1/2
	12	(Prefix)-12-HT24	37-1/4	74-1/2
	18	(Prefix)-18-HT24	40-1/4	80-1/2
	24	(Prefix)-24-HT24	43-1/4	86-1/2
36	30	(Prefix)-30-HT24	46-1/4	92-1/2
	36	(Prefix)-36-HT24	49-1/4	98-1/2
	6	(Prefix)-06-HT36	46-1/4	92-1/2
	9	(Prefix)-09-HT36	47-3/4	95-1/2
	12	(Prefix)-12-HT36	49-1/4	98-1/2
	18	(Prefix)-18-HT36	52-1/4	104-1/2
36	24	(Prefix)-24-HT36	55-1/4	110-1/2
	30	(Prefix)-30-HT36	58-1/4	116-1/2
	36	(Prefix)-36-HT36	61-1/4	122-1/2

Cross

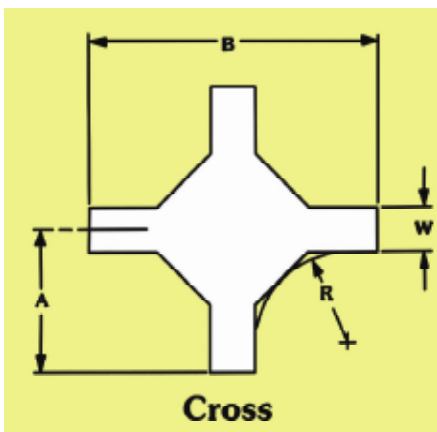

-R- Bend Radius (in.)	Tray Width (in.)	Catalog Number	A Inches	B Inches
12	6	(Prefix)-06-HX12	19-1/4	38
	9	(Prefix)-09-HX12	20-3/4	41
	12	(Prefix)-12-HX12	22-1/4	44
	18	(Prefix)-18-HX12	25-1/4	50
	24	(Prefix)-24-HX12	28-1/4	56
	30	(Prefix)-30-HX12	31-1/4	62
24	36	(Prefix)-36-HX12	34-1/4	68
	6	(Prefix)-06-HX24	34-1/4	68-1/2
	9	(Prefix)-09-HX24	35-3/4	71-1/2
	12	(Prefix)-12-HX24	37-1/4	74-1/2
	18	(Prefix)-18-HX24	40-1/4	80-1/2
	24	(Prefix)-24-HX24	43-1/4	86-1/2
36	30	(Prefix)-30-HX24	46-1/4	92-1/2
	36	(Prefix)-36-HX24	49-1/4	98-1/2
	6	(Prefix)-06-HX36	46-1/4	92-1/2
	9	(Prefix)-09-HX36	47-3/4	95-1/2
	12	(Prefix)-12-HX36	49-1/4	98-1/2
	18	(Prefix)-18-HX36	52-1/4	104-1/2
36	24	(Prefix)-24-HX36	55-1/4	110-1/2
	30	(Prefix)-30-HX36	58-1/4	116-1/2
	36	(Prefix)-36-HX36	61-1/4	122-1/2

FIBERGLASS

6" Horizontal Reducing Tee

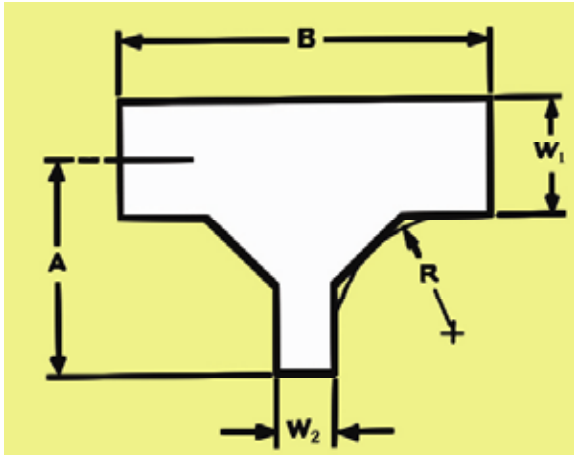

Tray Width		12" Radius		
W1 (in.)	W2 (in.)	Catalog No.	A (in.)	B (in.)
9	6	(Prefix)-09-06-HT12	20-3/4	38
12	6	(Prefix)-12-06-HT12	22-1/4	38
	9	(Prefix)-12-09-HT12	22-1/4	41
18	6	(Prefix)-18-06-HT12	25-1/4	38
	9	(Prefix)-18-09-HT12	25-1/4	41
	12	(Prefix)-18-12-HT12	25-1/4	44
24	6	(Prefix)-24-06-HT12	28-1/4	38
	9	(Prefix)-24-09-HT12	28-1/4	41
	12	(Prefix)-24-12-HT12	28-1/4	44
	18	(Prefix)-24-18-HT12	28-1/4	50
30	6	(Prefix)-30-06-HT12	31-1/4	38
	9	(Prefix)-30-09-HT12	31-1/4	41
	12	(Prefix)-30-12-HT12	31-1/4	44
	18	(Prefix)-30-18-HT12	31-1/4	50
	24	(Prefix)-30-24-HT12	31-1/4	56
36	6	(Prefix)-36-06-HT12	34-1/4	38
	9	(Prefix)-36-09-HT12	34-1/4	41
	12	(Prefix)-36-12-HT12	34-1/4	44
	18	(Prefix)-36-18-HT12	34-1/4	50
	24	(Prefix)-36-24-HT12	34-1/4	56
	30	(Prefix)-36-30-HT12	34-1/4	62

Tray Width		24" Radius			36" Radius	
W1 (in.)	W2 (in.)	Catalog No.	A (in.)	B (in.)	A (in.)	B (in.)
9	6	(Prefix)-09-06-HT*	35-3/4	68-1/2	47-3/4	92-1/2
12	6	(Prefix)-12-06-HT*	37-1/4	68-1/2	49-1/4	92-1/2
	9	(Prefix)-12-09-HT*	37-1/4	71-1/2	49-1/4	95-1/2
18	6	(Prefix)-18-06-HT*	40-1/4	68-1/2	52-1/4	92-1/2
	9	(Prefix)-18-09-HT*	40-1/4	71-1/1	52-1/4	95-1/2
	12	(Prefix)-18-12-HT*	40-1/4	74-1/2	52-1/4	98-1/2
24	6	(Prefix)-24-06-HT*	43-1/4	68-1/2	55-1/4	92-1/2
	9	(Prefix)-24-09-HT*	43-1/4	71-1/1	55-1/4	95-1/2
	12	(Prefix)-24-12-HT*	43-1/4	74-1/2	55-1/4	98-1/2
	18	(Prefix)-24-18-HT*	43-1/4	80-1/2	55-1/4	104-1/2
30	6	(Prefix)-30-06-HT*	46-1/4	68-1/2	58-1/4	92-1/2
	9	(Prefix)-30-09-HT*	46-1/4	71-1/1	58-1/4	95-1/2
	12	(Prefix)-30-12-HT*	46-1/4	74-1/2	58-1/4	98-1/2
	18	(Prefix)-30-18-HT*	46-1/4	80-1/2	58-1/4	104-1/2
	24	(Prefix)-30-24-HT*	46-1/4	86-1/2	58-1/4	110-1/2
36	6	(Prefix)-36-06-HT*	49-1/4	68-1/2	61-1/4	92-1/2
	9	(Prefix)-36-09-HT*	49-1/4	71-1/1	61-1/4	95-1/2
	12	(Prefix)-36-12-HT*	49-1/4	74-1/2	61-1/4	98-1/2
	18	(Prefix)-36-18-HT*	49-1/4	80-1/2	61-1/4	104-1/2
	24	(Prefix)-36-24-HT*	49-1/4	86-1/2	61-1/4	110-1/2
	30	(Prefix)-36-30-HT*	49-1/4	92-1/2	61-1/4	116-1/2

FIBERGLASS

6" Horizontal Expanding Tee

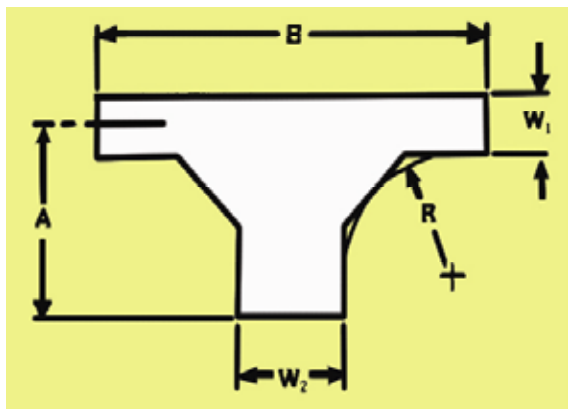

Tray Width		12" Radius		
W1 (in.)	W2 (in.)	Catalog No.	A (in.)	B (in.)
6	9	(Prefix)-06-09-HT12	19-1/4	41
	12	(Prefix)-06-12-HT12	19-1/4	44
	18	(Prefix)-06-18-HT12	19-1/4	50
	24	(Prefix)-06-24-HT12	19-1/4	56
	30	(Prefix)-06-30-HT12	19-1/4	62
9	36	(Prefix)-06-36-HT12	19-1/4	68
	12	(Prefix)-09-12-HT12	20-3/4	44
	18	(Prefix)-09-18-HT12	20-3/4	50
	24	(Prefix)-09-24-HT12	20-3/4	56
	30	(Prefix)-09-30-HT12	20-3/4	62
12	36	(Prefix)-09-36-HT12	20-3/4	68
	18	(Prefix)-12-18-HT12	22-1/4	50
	24	(Prefix)-12-24-HT12	22-1/4	56
	30	(Prefix)-12-30-HT12	22-1/4	62
18	36	(Prefix)-12-36-HT12	22-1/4	68
	24	(Prefix)-18-24-HT12	25-1/4	56
	30	(Prefix)-18-30-HT12	25-1/4	62
24	36	(Prefix)-18-36-HT12	25-1/4	68
	30	(Prefix)-24-30-HT12	28-1/4	62
30	36	(Prefix)-24-36-HT12	28-1/4	68
30	36	(Prefix)-30-36-HT12	31-1/4	68

Tray Width		24" Radius		36" Radius		
W1 (in.)	W2 (in.)	Catalog No.	A (in.)	B (in.)	A (in.)	B (in.)
6	9	(Prefix)-06-09-HT*	34-1/4	71-1/2	46-1/4	95-1/2
	12	(Prefix)-06-12-HT*	34-1/4	74-1/2	46-1/4	98-1/2
	18	(Prefix)-06-18-HT*	34-1/4	80-1/2	46-1/4	104-1/2
	24	(Prefix)-06-24-HT*	34-1/4	86-1/2	46-1/4	110-1/2
	30	(Prefix)-06-30-HT*	34-1/4	92-1/2	46-1/4	116-1/2
9	36	(Prefix)-06-36-HT*	34-1/4	98-1/2	46-1/4	122-1/2
	12	(Prefix)-09-12-HT*	35-3/4	74-1/2	47-3/4	98-1/2
	18	(Prefix)-09-18-HT*	35-3/4	80-1/2	47-3/4	104-1/2
	24	(Prefix)-09-24-HT*	35-3/4	86-1/2	47-3/4	110-1/2
	30	(Prefix)-09-30-HT*	35-3/4	92-1/2	47-3/4	116-1/2
12	36	(Prefix)-09-36-HT*	35-3/4	98-1/2	47-3/4	122-1/2
	18	(Prefix)-12-18-HT*	37-1/4	80-1/2	49-1/4	104-1/2
	24	(Prefix)-12-24-HT*	37-1/4	86-1/2	49-1/4	110-1/2
	30	(Prefix)-12-30-HT*	37-1/4	92-1/2	49-1/4	116-1/2
18	36	(Prefix)-12-36-HT*	37-1/4	98-1/2	49-1/4	122-1/2
	24	(Prefix)-18-24-HT*	40-1/4	86-1/2	52-1/4	110-1/2
	30	(Prefix)-18-30-HT*	40-1/4	92-1/2	52-1/4	116-1/2
24	36	(Prefix)-18-36-HT*	40-1/4	98-1/2	52-1/4	122-1/2
	30	(Prefix)-24-30-HT*	43-1/4	92-1/2	55-1/4	116-1/2
30	36	(Prefix)-24-36-HT*	43-1/4	98-1/2	55-1/4	122-1/2
30	36	(Prefix)-30-36-HT*	46-1/4	98-1/2	58-1/4	122-1/2

FIBERGLASS

6" Horizontal Expanding/ Reducing Cross

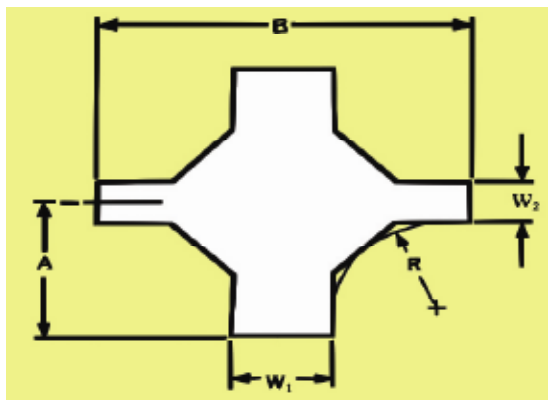

Tray Width			12" Radius	
W1 (in.)	W2 (in.)	Catalog No.	A (in.)	B (in.)
6	9	(Prefix)-06-09-HX*	22-1/4	47-1/2
	12	(Prefix)-06-12-HX*	22-1/4	50-1/2
	18	(Prefix)-06-18-HX*	22-1/4	56-1/2
	24	(Prefix)-06-24-HX*	22-1/4	62-1/2
	30	(Prefix)-06-30-HX*	22-1/4	68-1/2
	36	(Prefix)-06-36-HX*	22-1/4	74-1/2
9	12	(Prefix)-09-12-HX*	23-3/4	50-1/2
	18	(Prefix)-09-18-HX*	23-3/4	56-1/2
	24	(Prefix)-09-24-HX*	23-3/4	62-1/2
	30	(Prefix)-09-30-HX*	23-3/4	68-1/2
	36	(Prefix)-09-36-HX*	23-3/4	74-1/2
12	18	(Prefix)-12-18-HX*	25-1/4	56-1/2
	24	(Prefix)-12-24-HX*	25-1/4	62-1/2
	30	(Prefix)-12-30-HX*	25-1/4	68-1/2
	36	(Prefix)-12-36-HX*	25-1/4	74-1/2
18	24	(Prefix)-18-24-HX*	28-1/4	62-1/2
	30	(Prefix)-18-30-HX*	28-1/4	68-1/2
	36	(Prefix)-18-36-HX*	28-1/4	74-1/2
24	30	(Prefix)-24-30-HX*	31-1/4	68-1/2
	36	(Prefix)-24-36-HX*	31-1/4	74-1/2
30	36	(Prefix)-30-36-HX*	34-1/4	74-1/2

Tray Width			24" Radius		36" Radius	
W1 (in.)	W2 (in.)	Catalog No.	A (in.)	B (in.)	A (in.)	B (in.)
6	9	(Prefix)-06-09-HX*	34-1/4	71-1/2	46-1/4	95-1/2
	12	(Prefix)-06-12-HX*	34-1/4	74-1/2	46-1/4	98-1/2
	18	(Prefix)-06-18-HX*	34-1/4	80-1/2	46-1/4	104-1/2
	24	(Prefix)-06-24-HX*	34-1/4	86-1/2	46-1/4	110-1/2
	30	(Prefix)-06-30-HX*	34-1/4	92-1/2	46-1/4	116-1/2
	36	(Prefix)-06-36-HX*	34-1/4	98-1/2	46-1/4	122-1/2
9	12	(Prefix)-09-12-HX*	35-3/4	74-1/2	47-3/4	98-1/2
	18	(Prefix)-09-18-HX*	35-3/4	80-1/2	47-3/4	104-1/2
	24	(Prefix)-09-24-HX*	35-3/4	86-1/2	47-3/4	110-1/2
	30	(Prefix)-09-30-HX*	35-3/4	92-1/2	47-3/4	116-1/2
	36	(Prefix)-09-36-HX*	35-3/4	98-1/2	47-3/4	122-1/2
12	18	(Prefix)-12-18-HX*	37-1/4	80-1/2	49-1/4	104-1/2
	24	(Prefix)-12-24-HX*	37-1/4	86-1/2	49-1/4	110-1/2
	30	(Prefix)-12-30-HX*	37-1/4	92-1/2	49-1/4	116-1/2
	36	(Prefix)-12-36-HX*	37-1/4	98-1/2	49-1/4	122-1/2
18	24	(Prefix)-18-24-HX*	40-1/4	86-1/2	52-1/4	110-1/2
	30	(Prefix)-18-30-HX*	40-1/4	92-1/2	52-1/4	116-1/2
	36	(Prefix)-18-36-HX*	40-1/4	98-1/2	52-1/4	122-1/2
24	30	(Prefix)-24-30-HX*	43-1/4	92-1/2	55-1/4	116-1/2
	36	(Prefix)-24-36-HX*	43-1/4	98-1/2	55-1/4	122-1/2
30	36	(Prefix)-30-36-HX*	46-1/4	98-1/2	58-1/4	122-1/2

6" Reducers

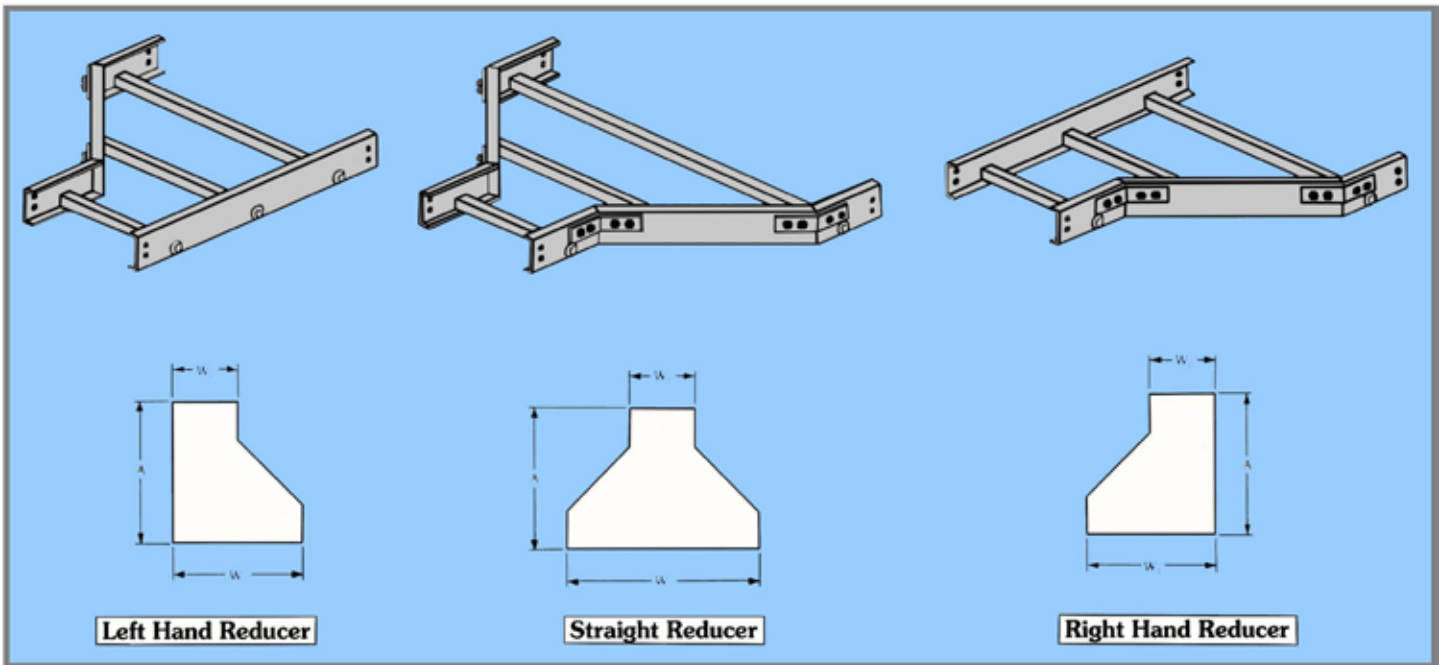

Tray Width		Left Hand Reducer		Straight Reducer		Right Hand Reducer	
W1 (in.)	W2 (in.)	Catalog Number	A (in.)	Catalog Number	A (in.)	Catalog Number	A (in.)
9	6	(Prefix)-09-LR06	17-1/2	(Prefix)-09-SR06	16	(Prefix)-09-RR06	17-1/2
12	6	(Prefix)-12-LR06	20-1/2	(Prefix)-12-SR06	17-1/2	(Prefix)-12-RR06	20-1/2
	9	(Prefix)-12-LR09	17-1/2	(Prefix)-12-SR09	16	(Prefix)-12-RR09	17-1/2
18	6	(Prefix)-18-LR06	26-1/2	(Prefix)-18-SR06	20-1/2	(Prefix)-18-RR06	26-1/2
	9	(Prefix)-18-LR09	23-1/2	(Prefix)-18-SR09	19	(Prefix)-18-RR09	23-1/2
	12	(Prefix)-18-LR12	20-1/2	(Prefix)-18-SR12	17-1/2	(Prefix)-18-RR12	20-1/2
24	6	(Prefix)-24-LR06	32-1/2	(Prefix)-24-SR06	23-1/2	(Prefix)-24-RR06	32-1/2
	9	(Prefix)-24-LR09	29-1/2	(Prefix)-24-SR09	22	(Prefix)-24-RR09	29-1/2
	12	(Prefix)-24-LR12	26-1/2	(Prefix)-24-SR12	20-1/2	(Prefix)-24-RR12	26-1/2
	18	(Prefix)-24-LR18	20-1/2	(Prefix)-24-SR18	17-1/2	(Prefix)-24-RR18	20-1/2
30	6	(Prefix)-30-LR06	38-1/2	(Prefix)-30-SR06	26-1/2	(Prefix)-30-RR06	38-1/2
	9	(Prefix)-30-LR09	35-1/2	(Prefix)-30-SR09	25	(Prefix)-30-RR09	35-1/2
	12	(Prefix)-30-LR12	32-1/2	(Prefix)-30-SR12	23-1/2	(Prefix)-30-RR12	32-1/2
	18	(Prefix)-30-LR18	26-1/2	(Prefix)-30-SR18	20-1/2	(Prefix)-30-RR18	26-1/2
	24	(Prefix)-30-LR24	20-1/2	(Prefix)-30-SR24	17-1/2	(Prefix)-30-RR24	20-1/2
36	6	(Prefix)-36-LR06	44-1/2	(Prefix)-36-SR06	29-1/2	(Prefix)-36-RR06	44-1/2
	9	(Prefix)-36-LR09	41-1/2	(Prefix)-36-SR09	28-26-1/2	(Prefix)-36-RR09	41-1/2
	12	(Prefix)-36-LR12	38-1/2	(Prefix)-36-SR12	1/2	(Prefix)-36-RR12	38-1/2
	18	(Prefix)-36-LR18	32-1/2	(Prefix)-36-SR18	23-1/2	(Prefix)-36-RR18	32-1/2
	24	(Prefix)-36-LR24	26-1/2	(Prefix)-36-SR24	20-1/2	(Prefix)-36-RR24	26-1/2
	30	(Prefix)-36-LR30	20-1/2	(Prefix)-36-SR30	17-1/2	(Prefix)-36-RR30	20-1/2

FIBERGLASS

6" Vertical Tees

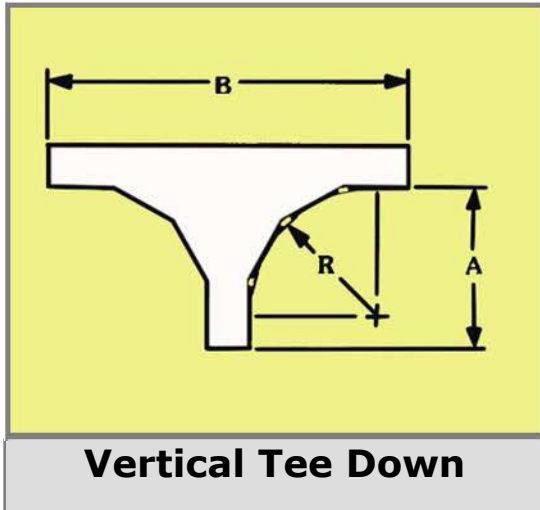

Vertical Tee Down

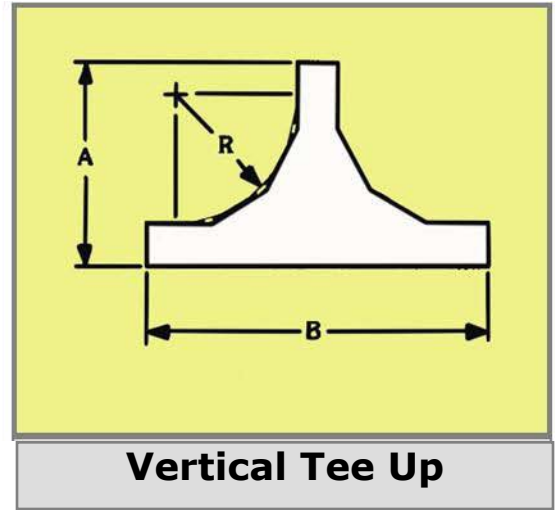

Vertical Tee Up

Two pair of splice plates with SS6 hardware included.

			Vertical Tee Down		Vertical Tee Up	
-R- Bend Radius (in.)	Tray Width (in.)	Catalog Number	A (in.)	B (in.)	A (in.)	B (in.)
12	6	(Prefix)-06-12	20-5/8	47-3/16	26-5/8	47-3/16
	9	(Prefix)-09-12				
	12	(Prefix)-12-12				
	18	(Prefix)-18-12				
	24	(Prefix)-24-12				
	30	(Prefix)-30-12				
24	6	(Prefix)-06-24	31-1/4	68-1/2	37-1/4	68-1/2
	9	(Prefix)-09-24				
	12	(Prefix)-12-24				
	18	(Prefix)-18-24				
	24	(Prefix)-24-24				
	30	(Prefix)-30-24				
36	6	(Prefix)-06-36	43	92	49	92
	9	(Prefix)-09-36				
	12	(Prefix)-12-36				
	18	(Prefix)-18-36				
	24	(Prefix)-24-36				
	30	(Prefix)-30-36				

FIBERGLASS

4P-09-24-120				
4	P-	09-	24-	120
Series	Material	Rung Spacing	Width	Length
Series: 4"	P=Polyester Resin V=Vinylester Resin	Rung Spacing: 6" 9" 12" 18"	Width: 6" 9" 12" 18" 24" 30" 36"	Length: 120 (10ft.) 240 (20ft.)

To obtain deflection at any span length for lighter loads than listed, multiply the load by the K factor. When trays are used in continuous spans, the deflection of the tray is reduced by as much as 50%.

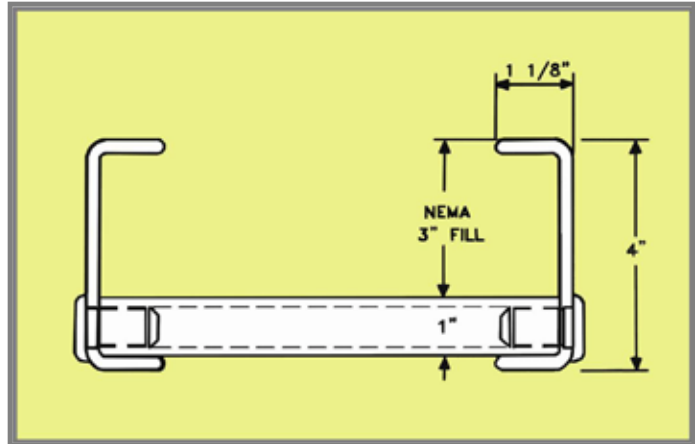

FIBERGLASS

Husky Series 4 **Safety Factor 1.5**

Span (Ft.)	10	12	14	16	18
Design Load Lbs./Ft.	157	109	80	61	48
Deflection	2.1	3.0	4.0	5.3	6.7
K Factor	0.013	0.028	0.050	0.087	0.140

*Loading—NEMA 12C *tested per NEMA FG-1, 12" rung spacing*

90° Horizontal Bend Dimensions.

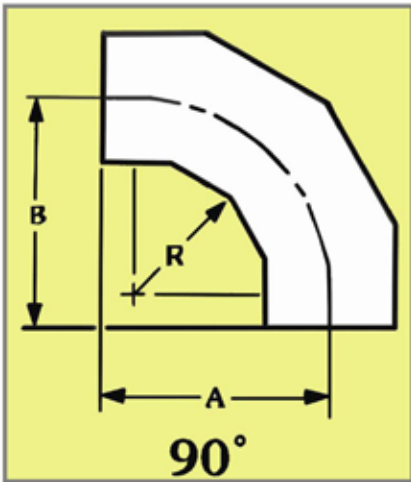

-R- Bend Radius (in.)	Tray Width (in.)	Catalog Number	A Inches	B Inches
12	6	(Prefix)-06-90HB12	20-3/8	20-3/8
	9	(Prefix)-09-90HB12	21-7/8	21-7/8
	12	*(Prefix)-12-90HB12	25-1/4	25-1/4
	18	*(Prefix)-18-90HB12	28-1/4	28-1/4
	24	*(Prefix)-24-90HB12	31-1/4	31-1/4
	30	*(Prefix)-30-90HB12	34-1/4	34-1/4
24	6	*(Prefix)-06-90HB24	34-1/4	34-1/4
	9	(Prefix)-09-90HB24	35-3/4	35-3/4
	12	*(Prefix)-12-90HB24	37-1/4	37-1/4
	18	*(Prefix)-18-90HB24	40-1/4	40-1/4
	24	*(Prefix)-24-90HB24	43-1/4	43-1/4
	30	(Prefix)-30-90HB24	46-1/4	46-1/4
36	6	(Prefix)-06-90HB36	46-1/4	46-1/4
	9	(Prefix)-09-90HB36	47-3/4	47-3/4
	12	(Prefix)-12-90HB36	49-1/4	49-1/4
	18	(Prefix)-18-90HB36	52-1/4	52-1/4
	24	(Prefix)-24-90HB36	55-1/4	55-1/4
	30	(Prefix)-30-90HB36	58-1/4	58-1/4
36	(Prefix)-36-90HB36	61-1/4	61-1/4	

45° Horizontal Bend Dimensions

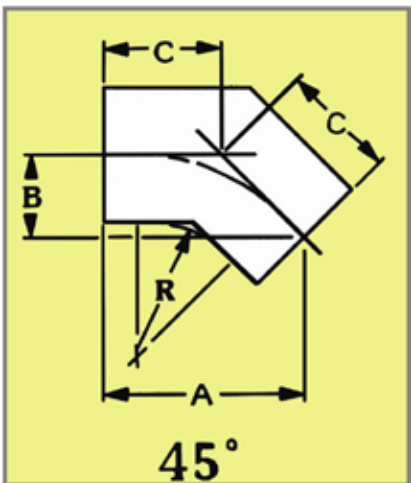

-R- Bend Radius (in.)	Tray Width (in.)	Catalog Number	A Inches	B Inches	C Inches
12	6	(Prefix)-06-45HB12	22-13/16	9-7/16	14-3/4
	9	(Prefix)-09-45HB12	23-7/8	9-7/8	15-15/16
	12	*(Prefix)-12-45HB12	17-7/8	7-3/8	10-7/16
	18	*(Prefix)-18-45HB12	20	8-1/4	11-1/16
	24	*(Prefix)-24-45HB12	22-1/16	9-1/8	12-15/16
	30	*(Prefix)-30-45HB12	24-3/16	10	14-3/16
24	6	*(Prefix)-06-45HB24	24-3/16	10	14-3/16
	9	(Prefix)-09-45HB24	25-1/4	10-1/2	16-3/4
	12	*(Prefix)-12-45HB24	26-5/16	10-15/16	15-7/16
	18	*(Prefix)-18-45HB24	28-7/16	11-13/16	16-11/16
	24	*(Prefix)-24-45HB24	30-9/16	12-11/16	17-15/16
	30	(Prefix)-30-45HB24	32-11/16	13-9/16	25-1/2
36	6	(Prefix)-06-45HB36	32-5/8	13-1/2	20-1/2
	9	(Prefix)-09-45HB36	33-11/16	13-15/16	21-11/16
	12	(Prefix)-12-45HB36	34-3/4	14-3/8	22-15/16
	18	(Prefix)-18-45HB36	36-7/8	15-1/4	25-7/16
	24	(Prefix)-24-45HB36	39	16-3/16	27-15/16
	30	(Prefix)-30-45HB36	41-1/8	17-1/16	30-7/16
36	(Prefix)-36-45HB36	43-1/4	17-15/16	32-7/8	

* Denotes molded fitting.

90° Vertical Bend Dimensions

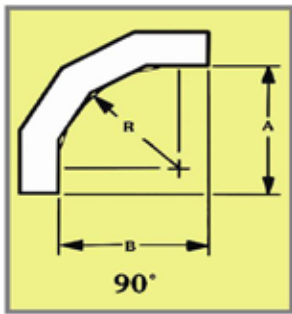

Vertical Outside Bend

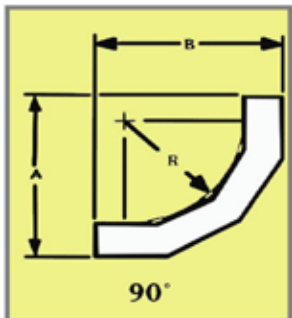

Vertical Inside Bend

Tray Width		Catalog No.	Vertical Outside Bend		Vertical Inside Bend	
W1 (in.)	W2 (in.)		A (in.)	B (in.)	A (in.)	B (in.)
12	6	*(Prefix)-06-90(*)12	19-1/4	19-1/4	23-1/4	23-1/4
	9	*(Prefix)-09-90(*)12				
	12	*(Prefix)-12-90(*)12				
	18	*(Prefix)-18-90(*)12				
	24	*(Prefix)-24-90(*)12				
	30	*(Prefix)-30-90(*)12				
	36	*(Prefix)-36-90(*)12				
24	6	(Prefix)-6-90(*)24	31	31	35-1/2	35-1/2
	9	(Prefix)-9-90(*)24				
	12	(Prefix)-12-90(*)24				
	18	(Prefix)-18-90(*)24				
	24	(Prefix)-24-90(*)24				
	30	(Prefix)-30-90(*)24				
	36	(Prefix)-36-90(*)24				
36	6	(Prefix)-6-90(*)24	43	43	48-1/2	48-1/2
	9	(Prefix)-9-90(*)24				
	12	(Prefix)-12-90(*)24				
	18	(Prefix)-18-90(*)24				
	24	(Prefix)-24-90(*)24				
	30	(Prefix)-30-90(*)24				
	36	(Prefix)-36-90(*)24				

45° Vertical Bend Dimensions

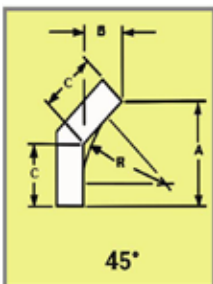

Vertical Outside Bend

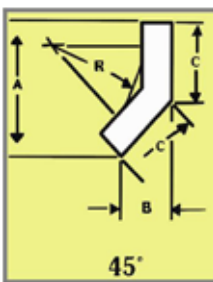

Vertical Inside Bend

-R-Bend Radius (in.)	Tray Width (in.)	Catalog Number	Vertical Outside Bend			Vertical Inside Bend		
			A In.	B In.	C In.	A In.	B In.	C In.
12	6	*(Prefix)-06-45(*)12	13-5/8	5-5/8	8	16-7/8	2-13/16	6-13/16
	9	*(Prefix)-09-45(*)12						
	12	*(Prefix)-12-45(*)12						
	18	*(Prefix)-18-45(*)12						
	24	*(Prefix)-24-45(*)12						
	30	*(Prefix)-30-45(*)12						
	36	*(Prefix)-36-45(*)12						
24	6	(Prefix)-6-45(*)24	22-1/16	9-1/8	12-15/16	24-15/16	10-5/16	14-5/8
	9	(Prefix)-9-45(*)24						
	12	(Prefix)-12-45(*)24						
	18	(Prefix)-18-45(*)24						
	24	(Prefix)-24-45(*)24						
	30	(Prefix)-30-45(*)24						
	36	(Prefix)-36-45(*)24						
36	6	(Prefix)-6-45(*)36	37-7/16	15-1/2	21-15/16	40-5/16	16-11/16	23-5/8
	9	(Prefix)-9-45(*)36						
	12	(Prefix)-12-45(*)36						
	18	(Prefix)-18-45(*)36						
	24	(Prefix)-24-45(*)36						
	30	(Prefix)-30-45(*)36						
	36	(Prefix)-36-45(*)36						

Note: Dimensions are for reference only, when critical, contact factory. Consult factory for availability of molded fittings. * Insert VO for vertical outside bend or VI for vertical inside bend.

FIBERGLASS

4" Horizontal Tee & Cross

Horizontal Tee

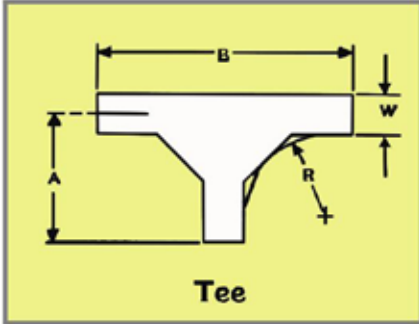

-R- Bend Radius (in.)	Tray Width (in.)	Catalog Number	A Inches	B Inches
12	6	*(Prefix)-06-HT12	22-1/4	44-1/2
	9	*(Prefix)-09-HT12	23-3/4	47-1/2
	12	*(Prefix)-12-HT12	25-1/4	50-1/2
	18	*(Prefix)-18-HT12	28-1/4	56-1/2
	24	*(Prefix)-24-HT12	31-1/4	62-1/2
	30	*(Prefix)-30-HT12	34-1/4	68-1/2
24	36	*(Prefix)-36-HT12	37-1/4	74-1/2
	6	*(Prefix)-06-HT24	34-1/4	68-1/2
	9	*(Prefix)-09-HT24	35-3/4	71-1/2
	12	*(Prefix)-12-HT24	37-1/4	74-1/2
	18	*(Prefix)-18-HT24	40-1/4	80-1/2
	24	*(Prefix)-24-HT24	43-1/4	86-1/2
36	30	*(Prefix)-30-HT24	46-1/4	92-1/2
	36	*(Prefix)-36-HT24	49-1/4	98-1/2
	6	(Prefix)-06-HT36	46-1/4	92-1/2
	9	(Prefix)-09-HT36	47-3/4	95-1/2
	12	(Prefix)-12-HT36	49-1/4	98-1/2
	18	(Prefix)-18-HT36	52-1/4	104-1/2
24	(Prefix)-24-HT36	55-1/4	110-1/2	
30	(Prefix)-30-HT36	58-1/4	116-1/2	
36	(Prefix)-36-HT36	61-1/4	122-1/2	

Cross

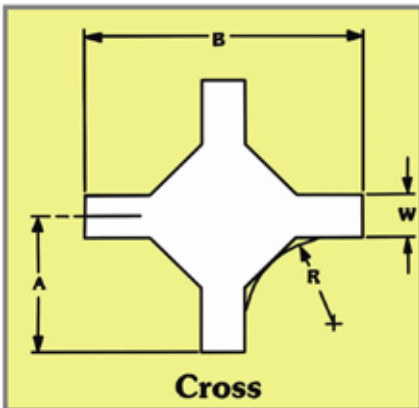

-R- Bend Radius (in.)	Tray Width (in.)	Catalog Number	A Inches	B Inches
12	6	*(Prefix)-06-HX12	22-1/4	44-1/2
	9	*(Prefix)-09-HX12	23-3/4	47-1/2
	12	*(Prefix)-12-HX12	25-1/4	50-1/2
	18	*(Prefix)-18-HX12	28-1/4	56-1/2
	24	*(Prefix)-24-HX12	31-1/4	62-1/2
	30	*(Prefix)-30-HX12	34-1/4	68-1/2
24	36	*(Prefix)-36-HX12	37-1/4	74-1/2
	6	*(Prefix)-06-HX24	34-1/4	68-1/2
	9	*(Prefix)-09-HX24	35-3/4	71-1/2
	12	*(Prefix)-12-HX24	37-1/4	74-1/2
	18	*(Prefix)-18-HX24	40-1/4	80-1/2
	24	*(Prefix)-24-HX24	43-1/4	86-1/2
36	30	*(Prefix)-30-HX24	46-1/4	92-1/2
	36	*(Prefix)-36-HX24	49-1/4	98-1/2
	6	(Prefix)-06-HX36	46-1/4	92-1/2
	9	(Prefix)-09-HX36	47-3/4	95-1/2
	12	(Prefix)-12-HX36	49-1/4	98-1/2
	18	(Prefix)-18-HX36	52-1/4	104-1/2
24	(Prefix)-24-HX36	55-1/4	110-1/2	
30	(Prefix)-30-HX36	58-1/4	116-1/2	
36	(Prefix)-36-HX36	61-1/4	122-1/2	

* Denotes molded fitting.

4" Horizontal Reducing Tee

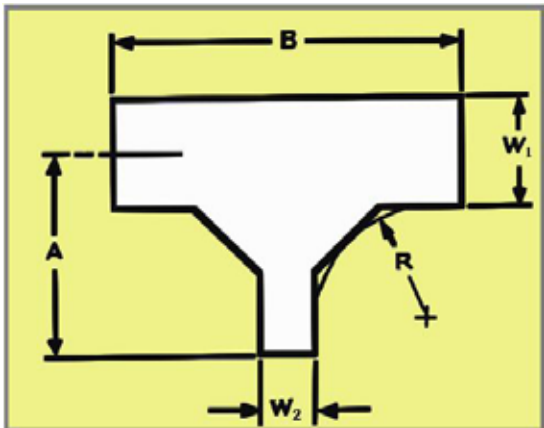

Tray Width			36" Radius	
W1 (in.)	W2 (in.)	Catalog No.	A (in.)	B (in.)
9	6	(Prefix)-09-06-HT36	47-3/4	92-1/2
12	6	(Prefix)-12-06-HT36	49-1/4	92-1/2
	9	(Prefix)-12-09-HT36	49-1/4	95-1/2
18	6	(Prefix)-18-06-HT36	52-1/4	92-1/2
	9	(Prefix)-18-09-HT36	52-1/4	95-1/2
	12	(Prefix)-18-12-HT36	52-1/4	98-1/2
24	6	(Prefix)-24-06-HT36	55-1/4	92-1/2
	9	(Prefix)-24-09-HT36	55-1/4	95-1/2
	12	(Prefix)-24-12-HT36	55-1/4	98-1/2
	18	(Prefix)-24-18-HT36	55-1/4	104-1/2
30	6	(Prefix)-30-06-HT36	58-1/4	92-1/2
	9	(Prefix)-30-09-HT36	58-1/4	95-1/2
	12	(Prefix)-30-12-HT36	58-1/4	98-1/2
	18	(Prefix)-30-18-HT36	58-1/4	104-1/2
	24	(Prefix)-30-24-HT36	58-1/4	110-1/2
36	6	(Prefix)-36-06-HT36	61-1/4	92-1/2
	9	(Prefix)-36-09-HT36	61-1/4	95-1/2
	12	(Prefix)-36-12-HT36	61-1/4	98-1/2
	18	(Prefix)-36-18-HT36	61-1/4	104-1/2
	24	(Prefix)-36-24-HT36	61-1/4	110-1/2
	30	(Prefix)-36-30-HT36	61-1/4	116-1/2

Tray Width			12" Radius		24" Radius	
W1 (in.)	W2 (in.)	Catalog No. (*Insert radius 12" or 24")	A (in.)	B (in.)	A (in.)	B (in.)
9	6	(Prefix)-09-06-HT*	23-3/4	44-1/2	35-3/4	68-1/2
12	6	(Prefix)-12-06-HT*	25-1/4	44-1/2	37-1/4	68-1/2
	9	(Prefix)-12-09-HT*	25-1/4	47-1/2	37-1/4	71-1/2
18	6	(Prefix)-18-06-HT*	28-1/4	44-1/2	40-1/4	68-1/2
	9	(Prefix)-18-09-HT*	28-1/4	47-1/2	40-1/4	71-1/2
	12	(Prefix)-18-12-HT*	28-1/4	50-1/2	40-1/4	74-1/2
24	6	(Prefix)-24-06-HT*	31-1/4	44-1/2	43-1/4	68-1/2
	9	(Prefix)-24-09-HT*	31-1/4	47-1/2	43-1/4	71-1/2
	12	(Prefix)-24-12-HT*	31-1/4	50-1/2	43-1/4	74-1/2
	18	(Prefix)-24-18-HT*	31-1/4	56-1/2	43-1/4	80-1/2
30	6	(Prefix)-30-06-HT*	34-1/4	44-1/2	46-1/4	68-1/2
	9	(Prefix)-30-09-HT*	34-1/4	47-1/2	46-1/4	71-1/2
	12	(Prefix)-30-12-HT*	34-1/4	50-1/2	46-1/4	74-1/2
	18	(Prefix)-30-18-HT*	34-1/4	56-1/2	46-1/4	80-1/2
	24	(Prefix)-30-24-HT*	34-1/4	62-1/2	46-1/4	86-1/2
36	6	(Prefix)-36-06-HT*	37-1/4	44-1/2	49-1/4	68-1/2
	9	(Prefix)-36-09-HT*	37-1/4	47-1/2	49-1/4	71-1/2
	12	(Prefix)-36-12-HT*	37-1/4	50-1/2	49-1/4	74-1/2
	18	(Prefix)-36-18-HT*	37-1/4	56-1/2	49-1/4	80-1/2
	24	(Prefix)-36-24-HT*	37-1/4	62-1/2	49-1/4	86-1/2
	30	(Prefix)-36-30-HT*	37-1/4	68-1/2	49-1/4	92-1/2

* Denotes molded fitting.

FIBERGLASS

4" Horizontal Expanding Tee

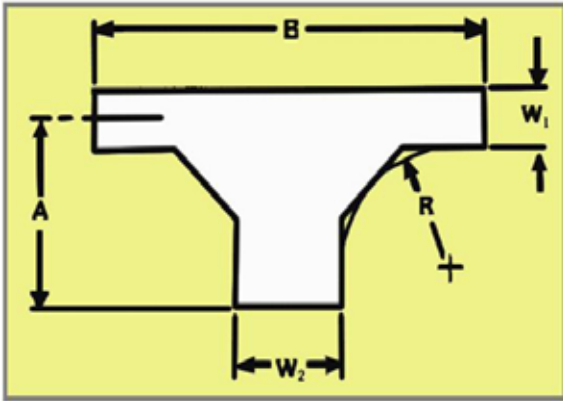

Tray Width		Catalog No.	36" Radius	
W1 (in.)	W2 (in.)		A (in.)	B (in.)
6	9	(Prefix)-06-09-HT36	46-1/4	95-1/2
	12	(Prefix)-06-12-HT36	46-1/4	98-1/2
	18	(Prefix)-06-18-HT36	46-1/4	104-1/2
	24	(Prefix)-06-24-HT36	46-1/4	110-1/2
	30	(Prefix)-06-30-HT36	46-1/4	116-1/2
9	36	(Prefix)-06-36-HT36	46-1/4	122-1/2
	12	(Prefix)-09-12-HT36	47-3/4	98-1/2
	18	(Prefix)-09-18-HT36	47-3/4	104-1/2
	24	(Prefix)-09-24-HT36	47-3/4	110-1/2
	30	(Prefix)-09-30-HT36	47-3/4	116-1/2
12	36	(Prefix)-09-36-HT36	47-3/4	122-1/2
	18	(Prefix)-12-18-HT36	48-1/4	104-1/2
	24	(Prefix)-12-24-HT36	48-1/4	110-1/2
	30	(Prefix)-12-30-HT36	48-1/4	116-1/2
18	36	(Prefix)-12-36-HT36	48-1/4	122-1/2
	24	(Prefix)-18-24-HT36	52-1/4	110-1/2
	30	(Prefix)-18-30-HT36	52-1/4	116-1/2
24	36	(Prefix)-18-36-HT36	52-1/4	122-1/2
	30	(Prefix)-24-30-HT36	55-1/4	116-1/2
36	(Prefix)-24-36-HT36	55-1/4	122-1/2	
30	(Prefix)-30-36-HT36	(Prefix)-30-36-HT36	58-1/4	122-1/2

Tray Width		Catalog No. (*Insert radius 12" or 24")	12" Radius		24" Radius	
W1 (in.)	W2 (in.)		A (in.)	B (in.)	A (in.)	B (in.)
6	9	(Prefix)-06-09-HT*	22-1/4	47-1/2	34-1/4	72-1/2
	12	(Prefix)-06-12-HT*	22-1/4	50-1/2	34-1/4	74-1/2
	18	(Prefix)-06-18-HT*	22-1/4	56-1/2	34-1/4	80-1/2
	24	(Prefix)-06-24-HT*	22-1/4	62-1/2	34-1/4	86-1/2
	30	(Prefix)-06-30-HT*	22-1/4	68-1/2	34-1/4	92-1/2
	36	(Prefix)-06-36-HT*	22-1/4	74-1/2	34-1/4	98-1/2
9	12	(Prefix)-09-12-HT*	23-3/4	50-1/2	35-3/4	74-1/2
	18	(Prefix)-09-18-HT*	23-3/4	56-1/2	35-3/4	80-1/2
	24	(Prefix)-09-24-HT*	23-3/4	62-1/2	35-3/4	86-1/2
	30	(Prefix)-09-30-HT*	23-3/4	68-1/2	35-3/4	92-1/2
	36	(Prefix)-09-36-HT*	23-3/4	74-1/2	35-3/4	98-1/2
12	18	(Prefix)-12-18-HT*	25-1/4	56-1/2	37-1/4	80-1/2
	24	(Prefix)-12-24-HT*	25-1/4	62-1/2	37-1/4	86-1/2
	30	(Prefix)-12-30-HT*	25-1/4	68-1/2	37-1/4	92-1/2
	36	(Prefix)-12-36-HT*	25-1/4	74-1/2	37-1/4	98-1/2
18	24	(Prefix)-18-24-HT*	28-1/4	62-1/2	40-1/4	86-1/2
	30	(Prefix)-18-30-HT*	28-1/4	68-1/2	40-1/4	92-1/2
	36	(Prefix)-18-36-HT*	28-1/4	74-1/2	40-1/4	98-1/2
24	30	(Prefix)-24-30-HT*	31-1/4	68-1/2	43-1/4	92-1/2
	36	(Prefix)-24-36-HT*	31-1/4	74-1/2	43-1/4	98-1/2
30	(Prefix)-30-36-HT*	(Prefix)-30-36-HT*	34-1/4	74-1/2	46-1/4	98-1/2

* Denotes molded fitting.

**4" Horizontal Expanding/
Reducing Cross**

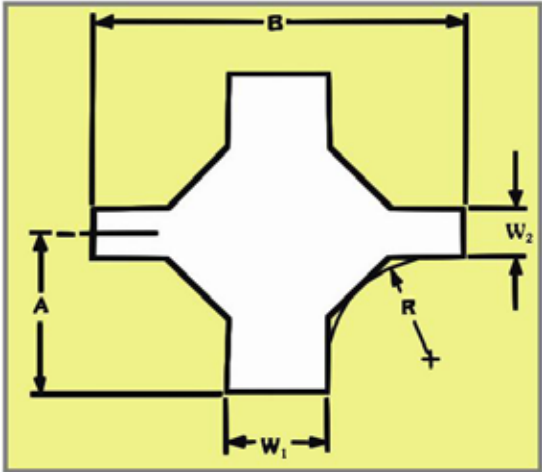

Tray Width		Catalog No.	12" Radius	
W1 (in.)	W2 (in.)		A (in.)	B (in.)
6	9	(Prefix)-06-09-HX36	22-1/4	47-1/2
	12	(Prefix)-06-12-HX36	22-1/4	50-1/2
	18	(Prefix)-06-18-HX36	22-1/4	56-1/2
	24	(Prefix)-06-24-HX36	22-1/4	62-1/2
	30	(Prefix)-06-30-HX36	22-1/4	68-1/2
9	36	(Prefix)-06-36-HX36	22-1/4	74-1/2
	12	(Prefix)-09-12-HX36	23-3/4	50-1/2
	18	(Prefix)-09-18-HX36	23-3/4	56-1/2
	24	(Prefix)-09-24-HX36	23-3/4	62-1/2
	30	(Prefix)-09-30-HX36	23-3/4	68-1/2
12	36	(Prefix)-09-36-HX36	23-3/4	74-1/2
	18	(Prefix)-12-18-HX36	25-1/4	56-1/2
	24	(Prefix)-12-24-HX36	25-1/4	62-1/2
	30	(Prefix)-12-30-HX36	25-1/4	68-1/2
18	36	(Prefix)-12-36-HX36	25-1/4	74-1/2
	24	(Prefix)-18-24-HX36	28-1/4	62-1/2
	30	(Prefix)-18-30-HX36	28-1/4	68-1/2
24	36	(Prefix)-18-36-HX36	28-1/4	74-1/2
	30	(Prefix)-24-30-HX36	31-1/4	68-1/2
36	(Prefix)-24-36-HX36	31-1/4	74-1/2	
30	36	(Prefix)-30-36-HX36	34-1/4	74-1/2

Tray Width		Catalog No. (*Insert radius 12" or 24")	24" Radius		36" Radius	
W1 (in.)	W2 (in.)		A (in.)	B (in.)	A (in.)	B (in.)
6	9	(Prefix)-06-09-HX*	34-1/4	71-1/2	46-1/4	95-1/2
	12	(Prefix)-06-12-HX*	34-1/4	74-1/2	46-1/4	98-1/2
	18	(Prefix)-06-18-HX*	34-1/4	80-1/2	46-1/4	104-1/2
	24	(Prefix)-06-24-HX*	34-1/4	86-1/2	46-1/4	110-1/2
	30	(Prefix)-06-30-HX*	34-1/4	92-1/2	46-1/4	116-1/2
	36	(Prefix)-06-36-HX*	34-1/4	98-1/2	46-1/4	122-1/2
9	12	(Prefix)-09-12-HX*	35-3/4	74-1/2	47-3/4	98-1/2
	18	(Prefix)-09-18-HX*	35-3/4	80-1/2	47-3/4	104-1/2
	24	(Prefix)-09-24-HX*	35-3/4	86-1/2	47-3/4	110-1/2
	30	(Prefix)-09-30-HX*	35-3/4	92-1/2	47-3/4	116-1/2
	36	(Prefix)-09-36-HX*	35-3/4	98-1/2	47-3/4	122-1/2
12	18	(Prefix)-12-18-HX*	37-1/4	80-1/2	49-1/4	104-1/2
	24	(Prefix)-12-24-HX*	37-1/4	86-1/2	49-1/4	110-1/2
	30	(Prefix)-12-30-HX*	37-1/4	92-1/2	49-1/4	116-1/2
	36	(Prefix)-12-36-HX*	37-1/4	98-1/2	49-1/4	122-1/2
18	24	(Prefix)-18-24-HX*	40-1/4	86-1/2	52-1/4	110-1/2
	30	(Prefix)-18-30-HX*	40-1/4	92-1/2	52-1/4	116-1/2
	36	(Prefix)-18-36-HX*	40-1/4	98-1/2	52-1/4	122-1/2
24	30	(Prefix)-24-30-HX*	43-1/4	92-1/2	55-1/4	116-1/2
	36	(Prefix)-24-36-HX*	43-1/4	98-1/2	55-1/4	122-1/2
30	36	(Prefix)-30-36-HX*	46-1/4	98-1/2	58-1/4	122-1/2

FIBERGLASS

4" Reducers

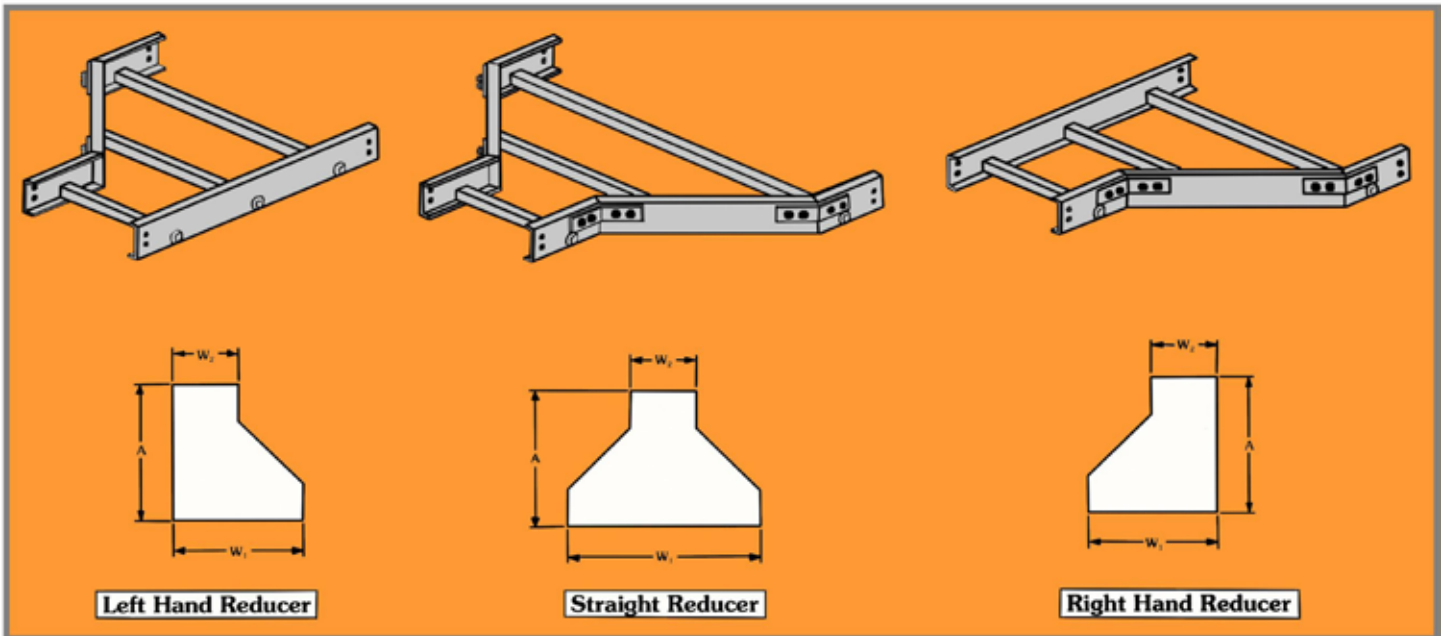

Tray Width		Left Hand Reducer		Straight Reducer		Right Hand Reducer	
W1 (in.)	W2 (in.)	Catalog Number	A (in.)	Catalog Number	A (in.)	Catalog Number	A (in.)
9	6	(Prefix)-09-LR06	17-1/2	(Prefix)-09-SR06	16	(Prefix)-09-RR06	17-1/2
12	6	(Prefix)-12-LR06	20-1/2	(Prefix)-12-SR06	17-1/2	(Prefix)-12-RR06	20-1/2
	9	(Prefix)-12-LR09	17-1/2	(Prefix)-12-SR09	16	(Prefix)-12-RR09	17-1/2
18	6	(Prefix)-18-LR06	26-1/2	(Prefix)-18-SR06	20-1/2	(Prefix)-18-RR06	26-1/2
	9	(Prefix)-18-LR09	23-1/2	(Prefix)-18-SR09	19	(Prefix)-18-RR09	23-1/2
	12	(Prefix)-18-LR12	20-1/2	(Prefix)-18-SR12	17-1/2	(Prefix)-18-RR12	20-1/2
24	6	(Prefix)-24-LR06	32-1/2	(Prefix)-24-SR06	23-1/2	(Prefix)-24-RR06	32-1/2
	9	(Prefix)-24-LR09	29-1/2	(Prefix)-24-SR09	22	(Prefix)-24-RR09	29-1/2
	12	(Prefix)-24-LR12	26-1/2	(Prefix)-24-SR12	20-1/2	(Prefix)-24-RR12	26-1/2
	18	(Prefix)-24-LR18	20-1/2	(Prefix)-24-SR18	17-1/2	(Prefix)-24-RR18	20-1/2
30	6	(Prefix)-30-LR06	38-1/2	(Prefix)-30-SR06	26-1/2	(Prefix)-30-RR06	38-1/2
	9	(Prefix)-30-LR09	35-1/2	(Prefix)-30-SR09	25	(Prefix)-30-RR09	35-1/2
	12	(Prefix)-30-LR12	32-1/2	(Prefix)-30-SR12	23-1/2	(Prefix)-30-RR12	32-1/2
	18	(Prefix)-30-LR18	26-1/2	(Prefix)-30-SR18	20-1/2	(Prefix)-30-RR18	26-1/2
	24	(Prefix)-30-LR24	20-1/2	(Prefix)-30-SR24	17-1/2	(Prefix)-30-RR24	20-1/2
36	6	(Prefix)-36-LR06	44-1/2	(Prefix)-36-SR06	29-1/2	(Prefix)-36-RR06	44-1/2
	9	(Prefix)-36-LR09	41-1/2	(Prefix)-36-SR09	28	(Prefix)-36-RR09	41-1/2
	12	(Prefix)-36-LR12	38-1/2	(Prefix)-36-SR12	26-1/2	(Prefix)-36-RR12	38-1/2
	18	(Prefix)-36-LR18	32-1/2	(Prefix)-36-SR18	23-1/2	(Prefix)-36-RR18	32-1/2
	24	(Prefix)-36-LR24	26-1/2	(Prefix)-36-SR24	20-1/2	(Prefix)-36-RR24	26-1/2
	30	(Prefix)-36-LR30	20-1/2	(Prefix)-36-SR30	17-1/2	(Prefix)-36-RR30	20-1/2

FIBERGLASS

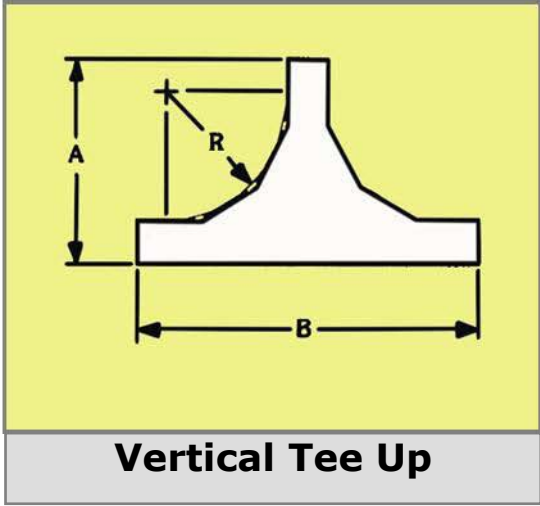
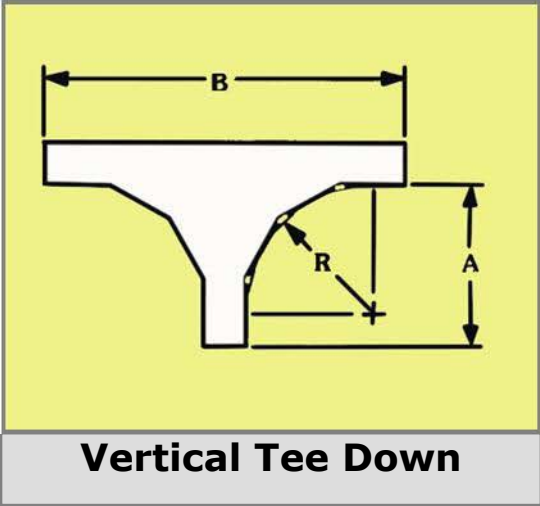

Two pair of splice plates with SS6 hardware included.

-R- Bend Radius (in.)	Tray Width (in.)	Catalog Number	Vertical Tee Down		Vertical Tee Up	
			A (in.)	B (in.)	A (in.)	B (in.)
12	6	*(Prefix)-06-12	19-1/4	42-1/2	23-1/4	42-1/2
	9	*(Prefix)-09-12				
	12	*(Prefix)-12-12				
	18	*(Prefix)-18-12				
	24	*(Prefix)-24-12				
	30	*(Prefix)-30-12				
36	*(Prefix)-36-12					
24	6	(Prefix)-06-24	31	66	35	66
	9	(Prefix)-09-24				
	12	(Prefix)-12-24				
	18	(Prefix)-18-24				
	24	(Prefix)-24-24				
	30	(Prefix)-30-24				
36	(Prefix)-36-24					
36	6	(Prefix)-06-36	43	90	47	90
	9	(Prefix)-09-36				
	12	(Prefix)-12-36				
	18	(Prefix)-18-36				
	24	(Prefix)-24-36				
	30	(Prefix)-30-36				

FIBERGLASS

3P-9-18-120				
Prefix				
3	P-	9-	18-	120
Series	Material	Rung Spacing	Width	Length
Series: 3"	P=Polyester Resin V=Vinylester Resin	Rung Spacing: 6" 9" 12" 18"	Width: 6" 9" 12" 18" 24" 30" 36"	Length: 120 (10ft.) 240 (20ft.)

To obtain deflection at any span length for lighter loads than listed, multiply the load by the K factor. When trays are used in continuous spans, the deflection of the tray is reduced by as much as 50%.

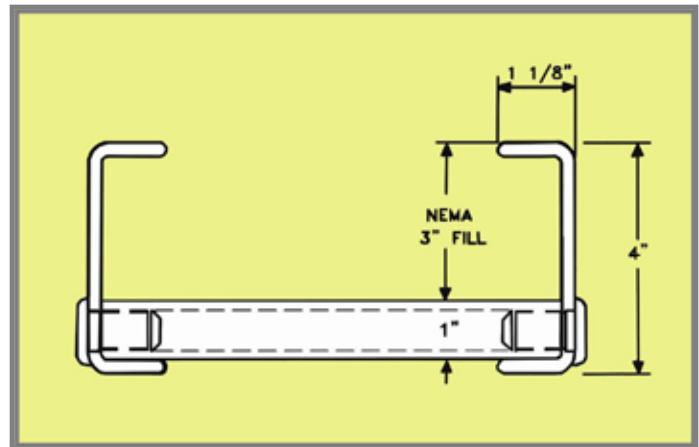

FIBERGLASS

Husky Series 3		Safety Factor 1.5				
Span (Ft.)	6	8	10	12	14	
Design Load Lbs./Ft.	257	145	93	64	47	
Deflection	1.3	2.3	3.7	5.3	7.2	
K Factor	0.005	0.016	0.040	0.083	0.153	
<i>Loading—NEMA 8C *tested per NEMA FG-1, 12" rung spacing</i>						

90° Horizontal Bend Dimensions.

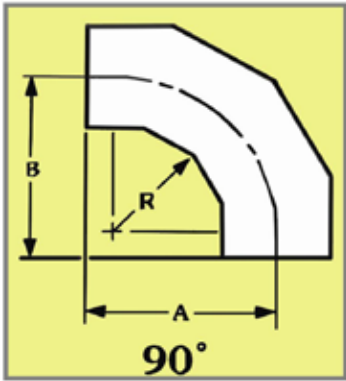

-R- Bend Radius (in.)	Tray Width (in.)	Catalog Number	A Inches	B Inches
12	6	(Prefix)-06-90HB12	20-3/8	20-3/8
	9	(Prefix)-09-90HB12	21-7/8	21-7/8
	12	(Prefix)-12-90HB12	23-3/8	23-3/8
	18	(Prefix)-18-90HB12	26-3/8	26-3/8
	24	(Prefix)-24-90HB12	29-3/8	29-3/8

45° Horizontal Bend Dimensions

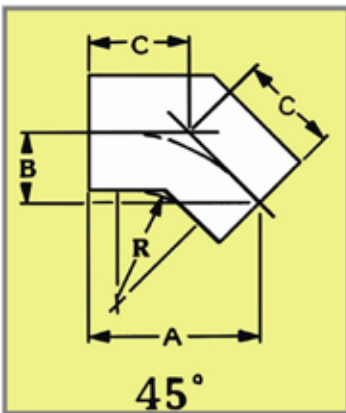

-R- Bend Radius (in.)	Tray Width (in.)	Catalog Number	A Inches	B Inches	C Inches
12	6	(Prefix)-06-45HB12	22-13/16	9-7/16	13-3/8
	9	(Prefix)-09-45HB12	23-7/8	9-7/8	14
	12	(Prefix)-12-45HB12	24-7/8	10-5/16	14-5/8
	18	(Prefix)-18-45HB12	27	11-3/16	15-7/8
	24	(Prefix)-24-45HB12	29-3/16	12-1/16	17-1/8

Horizontal Tee

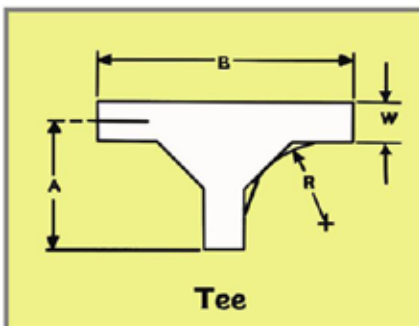

-R- Bend Radius (in.)	Tray Width (in.)	Catalog Number	A Inches	B Inches
12	6	(Prefix)-06-HT12	19-1/4	38
	9	(Prefix)-09-HT12	20-3/4	41-1/2
	12	(Prefix)-12-HT12	22-1/4	44-1/2
	18	(Prefix)-18-HT12	25-1/4	50-1/2
	24	(Prefix)-24-HT12	28-1/4	56-1/2

FIBERGLASS

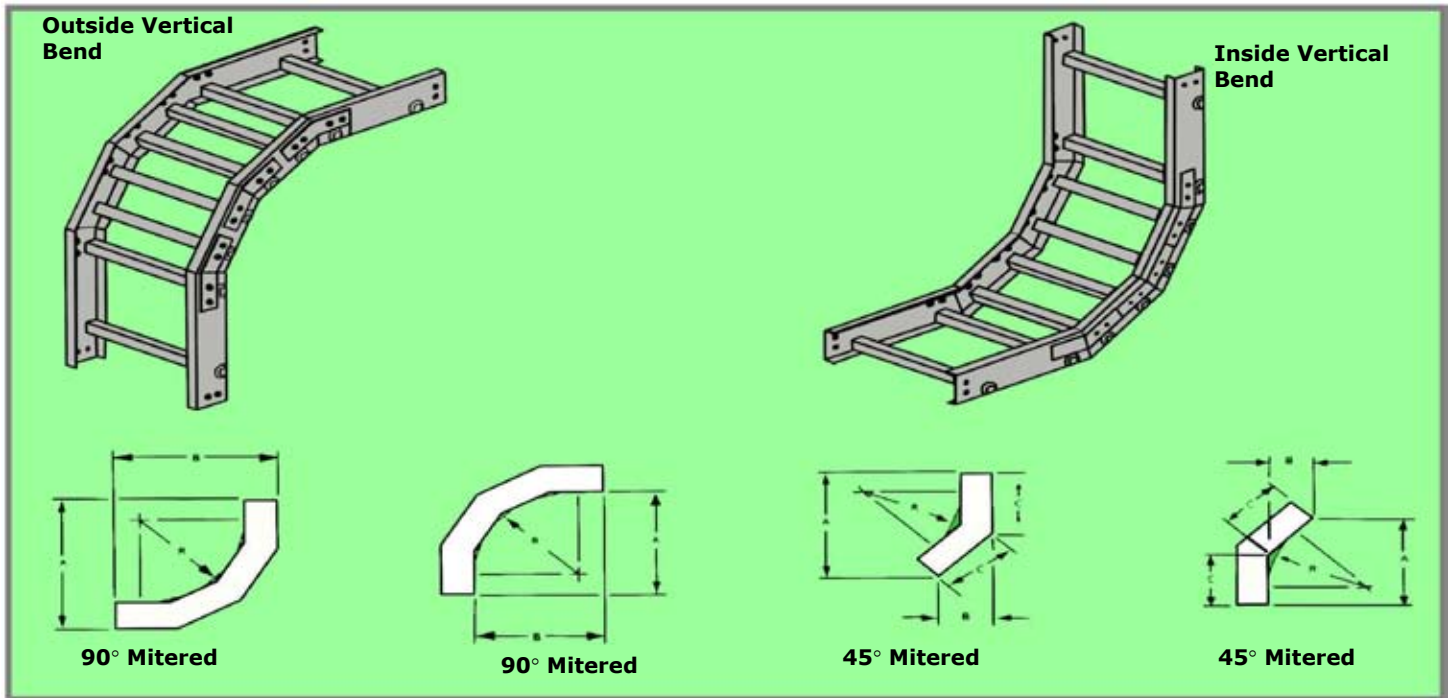

90° Vertical Bend Dimensions

-R- Bend Radius (in.)	Tray Width (in.)	Catalog Number	Vertical Outside Bend		Vertical Inside Bend	
			A In.	B In.	A In.	B In.
12	6	(Prefix)-06-90(*)12	20-15/16	20-15/16	26-15/16	26-15/16
	9	(Prefix)-09-90(*)12				
	12	(Prefix)-12-90(*)12				
	18	(Prefix)-18-90(*)12				
	24	(Prefix)-24-90(*)12				

45° Vertical Bend Dimensions

-R- Bend Radius (in.)	Tray Width (in.)	Catalog Number	Vertical Outside Bend			Vertical Inside Bend		
			A In.	B In.	C In.	A In.	B In.	C In.
12	6	(Prefix)-06-45(*)12	20-1/2	8-1/2	13-1/4	22-5/8	9-3/8	13-1/4
	9	(Prefix)-09-45(*)12						
	12	(Prefix)-12-45(*)12						
	18	(Prefix)-18-45(*)12						
	24	(Prefix)-24-45(*)12						

(*) - insert VI for vertical inside or VO for vertical outside.

One pair of splice plates with SS6 hardware is included.

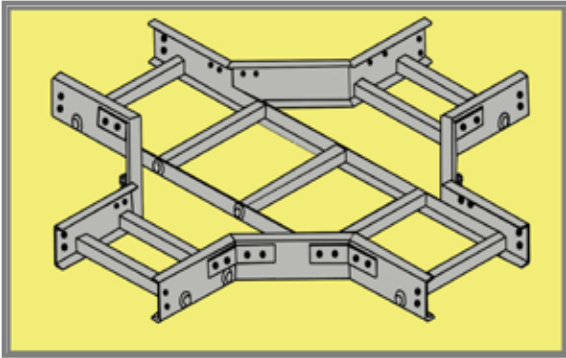

3" Horizontal Expanding/Reducing Cross

Tray Width			12" Radius	
W1 (in.)	W2 (in.)	Catalog No.	A (in.)	B (in.)
9	6	(Prefix)-09-06-HX12	19-1/4	41-1/2
12	6	(Prefix)-12-06-HX12	19-1/4	44-1/2
	9	(Prefix)-12-09-HX12	20-3/4	44-1/2
18	6	(Prefix)-18-06-HX12	19-1/4	50-1/2
	9	(Prefix)-18-09-HX12	20-3/4	50-1/2
	12	(Prefix)-18-12-HX12	22-1/4	50-1/2
24	6	(Prefix)-24-06-HX12	19-1/4	56-1/2
	9	(Prefix)-24-09-HX12	20-3/4	56-1/2
	12	(Prefix)-24-12-HX12	22-1/4	56-1/2
	18	(Prefix)-24-18-HX12	25-1/4	56-1/2

Three pair of splice plates with SS6 hardware are included.

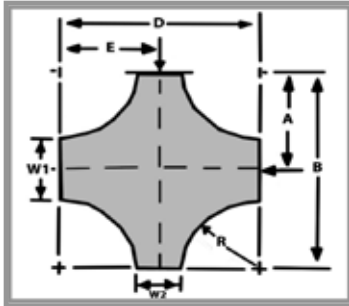

Mitered

Vertical Tee Down

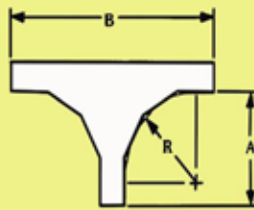

Vertical Tee Up

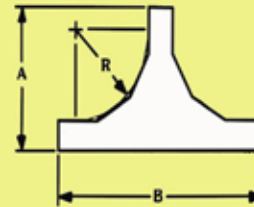

3" Vertical Tees—Down and Up

			Vertical Tee Down		Vertical Tee Up	
-R-Bend Radius (in.)	Tray Width	Catalog No.	A (in.)	B (in.)	A (in.)	B (in.)
12	6	(Prefix)-06-12	23-15/16	50-7/8	26-15/16	50-7/8
	9	(Prefix)-09-12				
	12	(Prefix)-12-12				
	18	(Prefix)-18-12				
	24	(Prefix)-24-12				

FIBERGLASS

3" Horizontal Reducing Tee

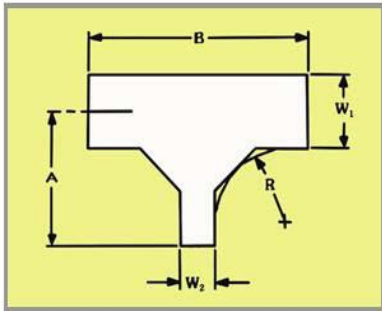
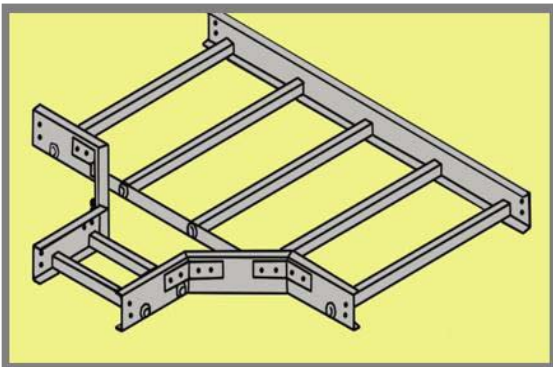

Mitered

Tray Width		Catalog No.	12" Radius	
W1 (in.)	W2 (in.)		A (in.)	B (in.)
9	6	(Prefix)-09-06-HT12	20-3/4	38-1/2
12	6	(Prefix)-12-06-HT12	22-1/4	38-1/2
	9	(Prefix)-12-09-HT12	22-1/4	41-1/2
18	6	(Prefix)-18-06-HT12	25-1/4	38-1/2
	9	(Prefix)-18-09-HT12	25-1/4	41-1/2
	12	(Prefix)-18-12-HT12	25-1/4	44-1/2
24	6	(Prefix)-24-06-HT12	28-1/4	38-1/2
	9	(Prefix)-24-09-HT12	28-1/4	41-1/2
	12	(Prefix)-24-12-HT12	28-1/4	44-1/2
	18	(Prefix)-24-18-HT12	28-1/4	50-1/2

Two pair of splice plates with SS6 hardware are included.

3" Horizontal Enlarging Tee

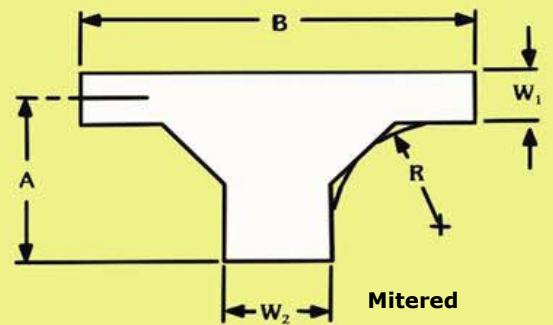
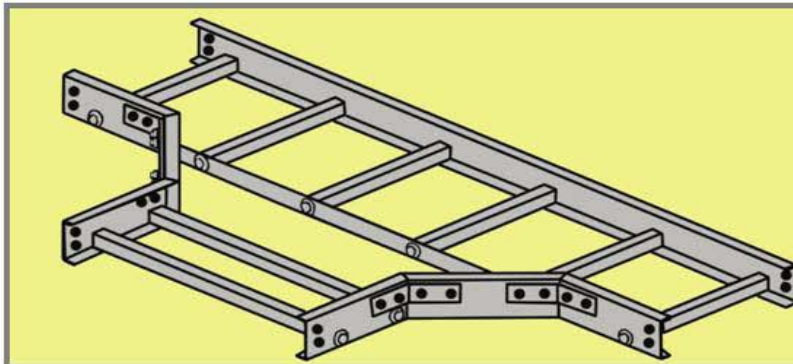

Mitered

Tray Width		Catalog No.	12" Radius	
W1 (in.)	W2 (in.)		A (in.)	B (in.)
6	9	(Prefix)-06-09-HT12	19-1/4	41-1/2
	12	(Prefix)-06-12-HT12	19-1/4	44-1/2
	18	(Prefix)-06-18-HT12	19-1/4	50-1/2
	24	(Prefix)-06-24-HT12	19-1/4	56-1/2
9	12	(Prefix)-09-12-HT12	20-3/4	44-1/2
	18	(Prefix)-09-18-HT12	20-3/4	50-1/2
	24	(Prefix)-09-24-HT12	20-3/4	56-1/2
12	18	(Prefix)-12-18-HT12	22-1/4	50-1/2
	24	(Prefix)-12-24-HT12	22-1/4	56-1/2
18	24	(Prefix)-18-24-HT12	25-1/4	56-1/2

Two pair of splice plates with SS6 hardware are included.

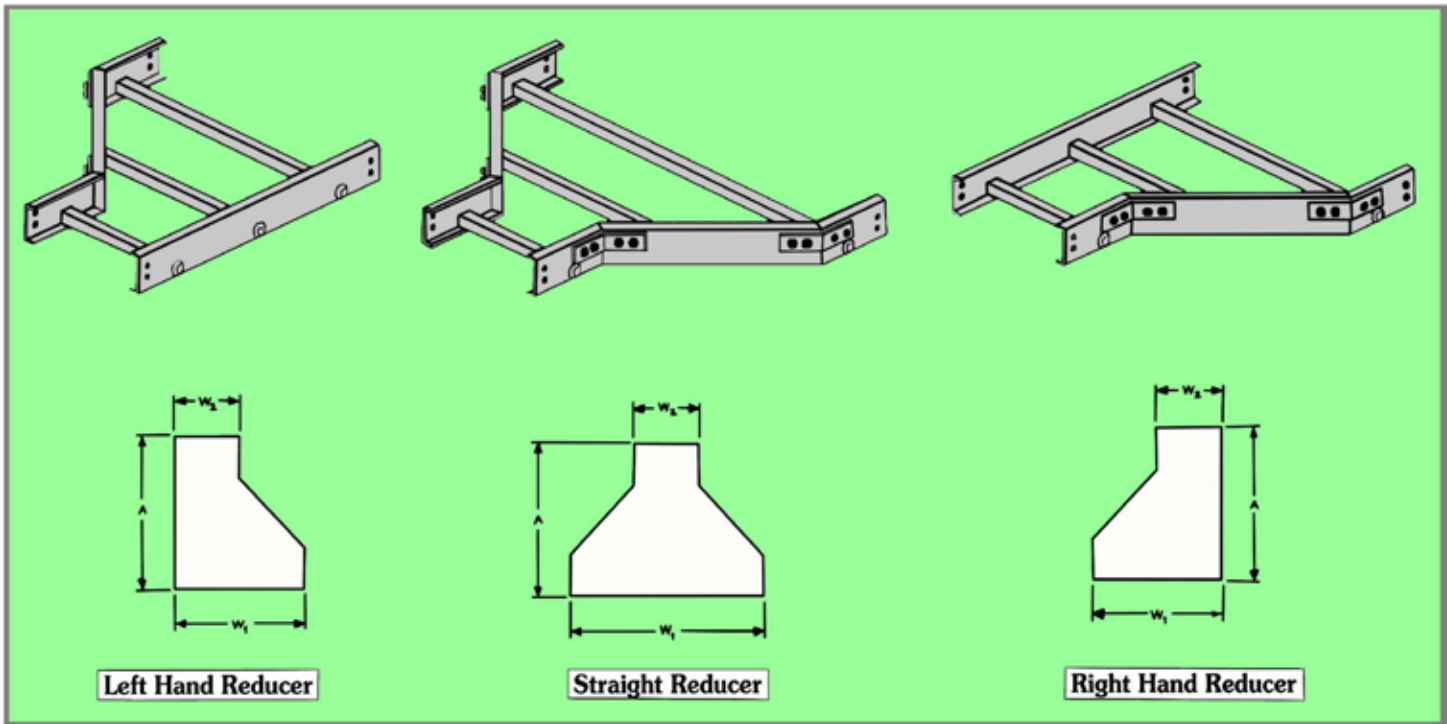

Tray Width		Left Hand Reducer		Straight Reducer		Right Hand Reducer	
W1 (in.)	W2 (in.)	Catalog Number	A (in.)	Catalog Number	A (in.)	Catalog Number	A (in.)
9	6	(Prefix)-09-LR06	17-1/2	(Prefix)-09-SR06	16	(Prefix)-09-RR06	17-1/2
12	6	(Prefix)-12-LR06	20-1/2	(Prefix)-12-SR06	17-1/2	(Prefix)-12-RR06	20-1/2
	9	(Prefix)-12-LR09	17-1/2	(Prefix)-12-SR09	16	(Prefix)-12-RR09	17-1/2
18	6	(Prefix)-18-LR06	26-1/2	(Prefix)-18-SR06	20-1/2	(Prefix)-18-RR06	26-1/2
	9	(Prefix)-18-LR09	23-1/2	(Prefix)-18-SR09	19	(Prefix)-18-RR09	23-1/2
	12	(Prefix)-18-LR12	20-1/2	(Prefix)-18-SR12	17-1/2	(Prefix)-18-RR12	20-1/2
24	6	(Prefix)-24-LR06	32-1/2	(Prefix)-24-SR06	23-1/2	(Prefix)-24-RR06	32-1/2
	9	(Prefix)-24-LR09	29-1/2	(Prefix)-24-SR09	22	(Prefix)-24-RR09	29-1/2
	12	(Prefix)-24-LR12	26-1/2	(Prefix)-24-SR12	20-1/2	(Prefix)-24-RR12	26-1/2
	18	(Prefix)-24-LR18	20-1/2	(Prefix)-24-SR18	17-1/2	(Prefix)-24-RR18	20-1/2

FIBERGLASS

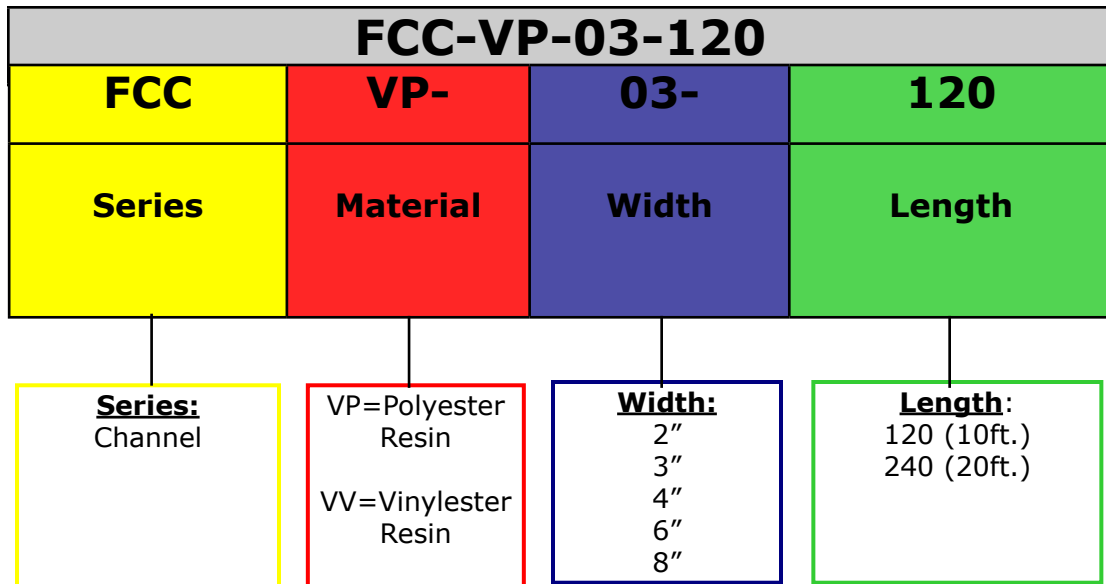

Husky Fiberglass Cable Channel Tray is available in Ventilated and Non-Ventilated Design and in Polyester or Vinylester material. The height information is listed below:

- 2"W—1" High
- 3"W - 1" High
- 4"W - 1-1/8" High
- 6"W - 1-5/8" High
- 8"W—2-3/16" High

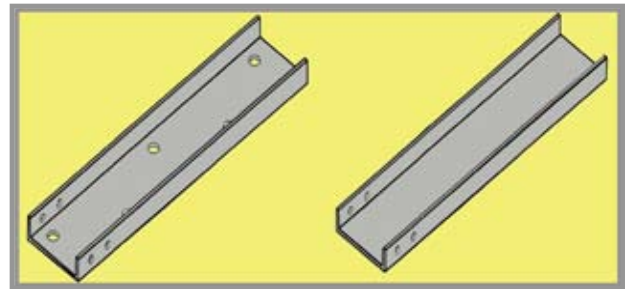

Note: Splice plates are not included.

VENTILATED			
Polyester	Vinylester	Width (in.)	Length (ft.)
FCCVP-02-120	FCCVV-02-120	2	10
FCCVP-02-240	FCCVV-02-240	2	20
FCCVP-03-120	FCCVV-03-120	3	10
FCCVP-03-240	FCCVV-03-240	3	20
FCCVP-04-120	FCCVV-04-120	4	10
FCCVP-04-240	FCCVV-04-240	4	20
FCCVP-06-120	FCCVV-06-120	6	10
FCCVP-06-240	FCCVV-06-240	6	20
FCCVP-08-120	FCCVV-08-120	8	10
FCCVP-08-240	FCCVV-08-240	8	20

NON-VENTILATED			
Polyester	Vinylester	Width (in.)	Length (ft.)
FCCNP-02-120	FCCNV-02-120	2	10
FCCNP-02-240	FCCNV-02-240	2	20
FCCNP-03-120	FCCNV-03-120	3	10
FCCNP-03-240	FCCNV-03-240	3	20
FCCNP-04-120	FCCNV-04-120	4	10
FCCNP-04-240	FCCNV-04-240	4	20
FCCNP-06-120	FCCNV-06-120	6	10
FCCNP-06-240	FCCNV-06-240	6	20
FCCNP-08-120	FCCNV-08-120	8	10
FCCNP-08-240	FCCNV-08-240	8	20

FIBERGLASS

Cable Channel Fittings

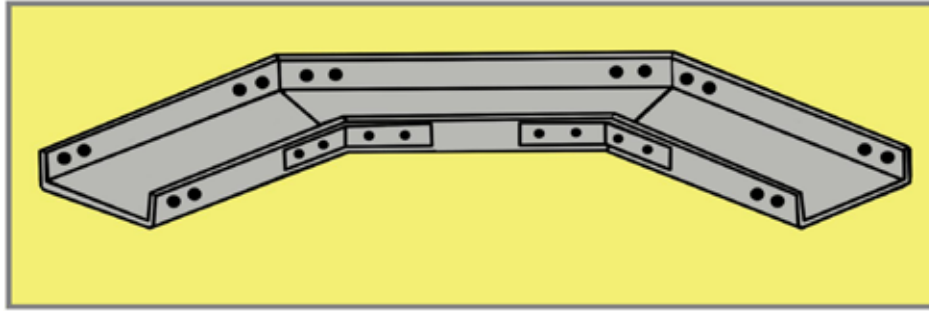

One pair of splice plates are included.

Horizontal	3" Wide	4" Wide	6" Wide	8" Wide
90°	FCCNP-03-90HB12	FCCNP-04-90HB12	FCCNP-06-90HB12	FCCNP-08-90HB12
45°	FCCNP-03-450HB12	FCCNP-04-45HB12	FCCNP-06-45HB12	FCCNP-08-45HB12

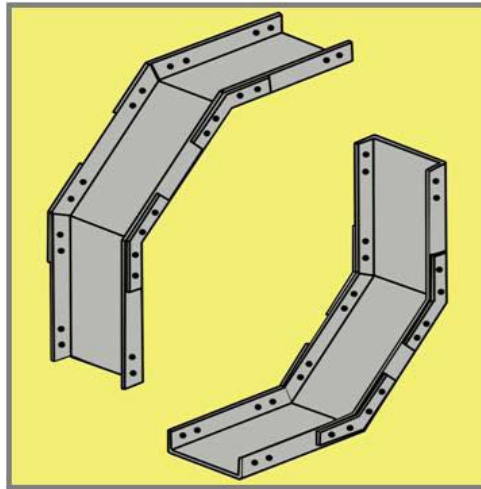

One pair of splice plates are included.

Vertical	3" Wide	4" Wide	6" Wide	8" Wide
90°	FCCNP-03-90V*12	FCCNP-04-90V*12	FCCNP-06-90V*12	FCCNP-08-90V*12
45°	FCCNP-03-45V*12	FCCNP-04-45V*12	FCCNP-06-45V*12	FCCNP-08-45V*12

*Notes: *Insert "O" for Vertical Out or "I" for Vertical In. For vinyl ester resin, "V" must be added appropriately to the part number in place of "P."*

Example: FCCNV-04-90HB12

FIBERGLASS

Cable Channel Fittings

Horizontal Tees

Catalog No.	Width (in.)
FCCNP-03-HT12	3
FCCNP-04-HT12	4
FCCNP-06-HT12	6
FCCNP-08-HT12	8

Two pairs of splice plates are included.

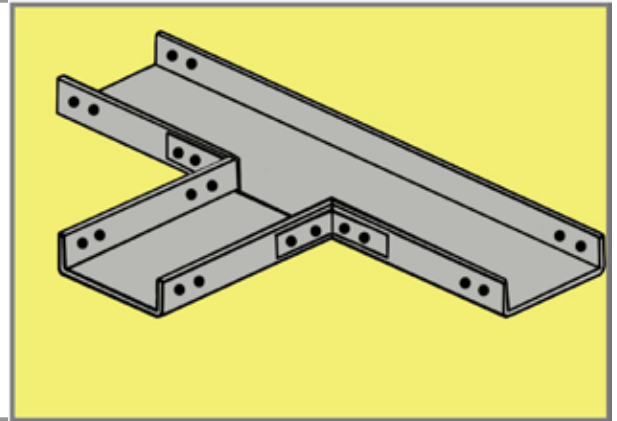

Horizontal Crosses

Catalog No.	Width (in.)
FCCNP-03-HX12	3
FCCNP-04-HX12	4
FCCNP-06-HX12	6
FCCNP-08-HX12	8

Three pairs of splice plates are included.

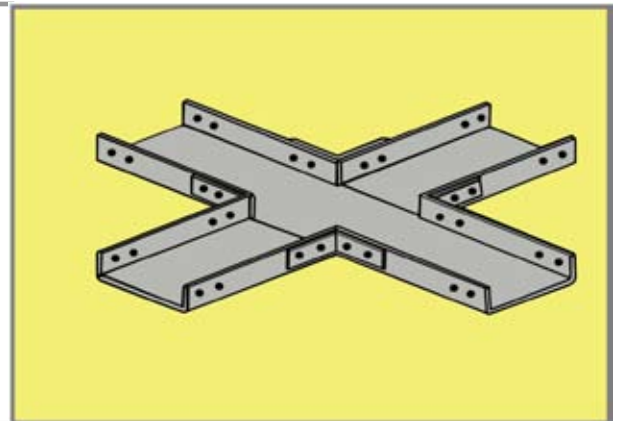

Cable Channel Splice Plates

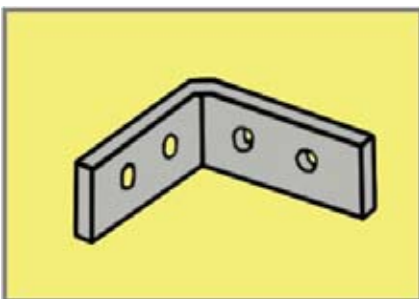

Horizontal 90° Splice Plates

Catalog #
XSS-1901H-SS6

Sold in pairs.

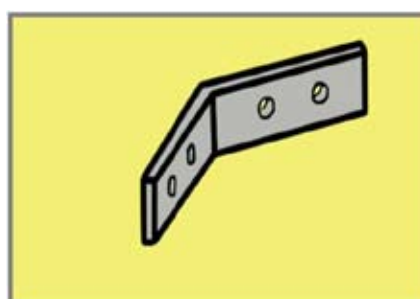

Horizontal 45° Splice Plates

Catalog #
XSS-1451H-SS6

Sold in pairs.

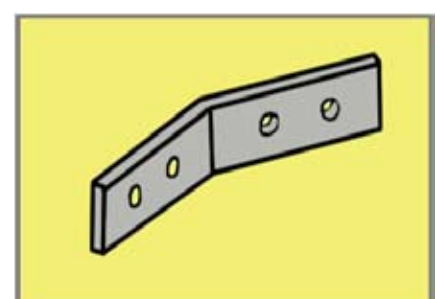

Horizontal 30° Splice Plates (pairs)

Catalog #
XSS-1301H-SS6

Sold in pairs.

Cable Channel Splice Plates

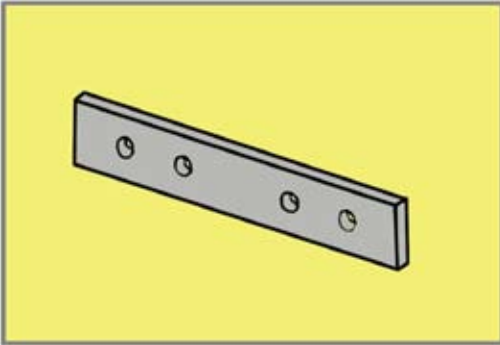

Splice Plates
Catalog #
XSS-1001-SS6
These splice plates are sold in pairs.

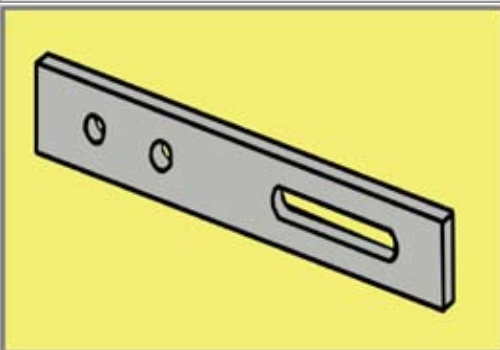

Expansion Splice Plates
Catalog #
XSS-1011-SS6
These splice plates are sold in pairs.

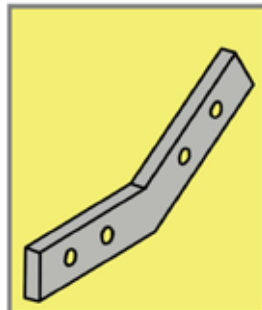

Vertical 30° Splice Plate
Catalog #
XSS-1301H-SS6
Sold in pairs.

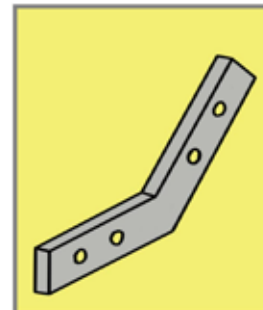

Vertical 45° Splice Plate
Catalog #
XSS-1451H-SS6
Sold in pairs.

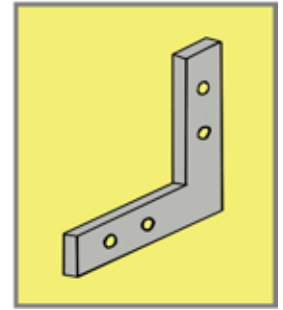

Vertical 90° Splice Plate
Catalog #
XSS-1901V-SS6
Sold in pairs.

FIBERGLASS

Channel Accessories

Part Number with Hardware Explanation—Part # XSS-0000*

*Indicates that additional information must be furnished to specify the type of hardware.

Hardware Option	316 Stainless Steel	Monel	Silicone Bronze	Husky Fiberglass
Replace * with	SS6	MO	SB	FR

Examples: XSS-4003—pair of 4 hole splice plates for 3" system without hardware
 XSS-4004 SS6—pair of 4 hole splice plates for 4" system with stainless steel hardware
 CSS-8006 SB—pair of 8 hole splice plates for 6" system with silicon bronze hardware

Recommended Fiberglass Cable Tray Specifications

1.0 Cable Tray Design

- 1.1 Cable Tray System shall be made of straight sections, fitting and accessories as defined in the latest NEMA standards publication FG-1.

2.0 Cable Tray Design

- 2.1 Straight section structural elements: side rails, rungs and splice plates shall be pultruded from glass fiber reinforced polyester or vinylester resin.
- 2.2 Pultruded shapes shall be constructed with a surface veil to ensure a resin-rich surface and ultraviolet resin.
- 2.3 Pultruded shapes shall meet ASTM E-84, Class 1 flame rating and self-extinguishing requirements of ASTM D-635.

3.0 Construction

- 3.1 Straight section lengths will be 120 inches (10ft.) or 240 inches (20ft.) standard.
- 3.2 Side rails will be inward "C" configuration and be pre-drilled to accept splice plates.
- 3.3 Loading depths for cable tray systems shall be 5", 3", or 2" as per NEMA FG-1 tolerances. Overall heights shall be 6", 4", or 3" respectively.

4.0 Fittings

- 4.1 Molded fittings shall be formed with a minimum 3" tangent following the radius.
- 4.2 3" or 5" loading depth systems shall have 90° and 45° molded fittings in 12" or 24" radius.
- 4.3 All fittings not included in 4.2 should be of mitered construction.
- 4.4 Width—useable inside tray width shall be 6", 9", 12", 18", 24", 30", or 36". Outside width shall not exceed inside by more than a total of 2".
- 4.5 Straight and expansion splice plates will be of stainless steel or Husky Fiberglass design with an eight bolt pattern in 5" fill systems and four bolt pattern in 3" and 2" fill systems.
- 4.6 Dimension tolerances will be per NEMA FG-1.
- 4.7 Cable tray must have integral connection between side rails and rungs consisting of non-metallic mechanical fasteners and adhesive bonding.

5.0 Manufacture

- 5.1 All manufacturing practices will be in accordance with NEMA FG-1.

Accessories

Standard Splice Plates

Included in needed quantities with tray section:

- ◆ Order only pairs of splice plates needed for field fabrication.
- ◆ SS6 hardware supplied as standard—use SS6 suffix.
- ◆ Other hardware available, specify by hardware suffix. Hardware other than SS6 is considered special.

	Height	Catalog No.
Stainless	6"	XSS-8006*
Steel	4"	XSS-4004*
	3"	XSS-4003*

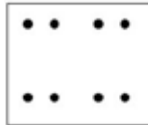

Expansion Splice Plate

- ◆ * = Hardware suffix needed to complete part number.

	Height	Catalog No.
Stainless	6"	XSS-8016*
Steel	4"	XSS-4014*
	3"	XSS-4013*



Blind End Plate

This plate forms a closure for any tray that dead ends.

- ◆ Furnished as on plate
- ◆ W = tray width
- ◆ * = hardware suffix needed to complete part number

	Height	Catalog No.
	6"	XBE-1186-W*
Husky Fiberglass	4"	XBE-1084-W*

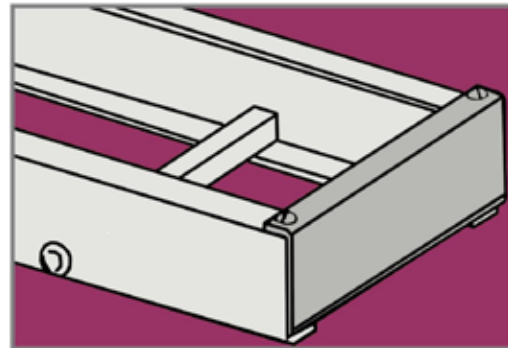

Horizontal Splice Plates

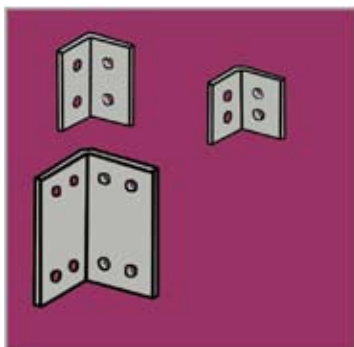

90° Horizontal Splice Plate

Catalog #

- XSS-8906H*
- XSS-4904H*
- XSS-4903H*

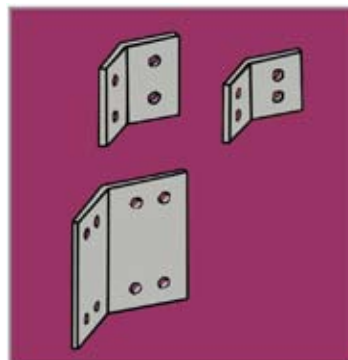

45° Horizontal Splice Plate

Catalog #

- XSS-8456H*
- XSS-4454H*
- XSS-4453H*

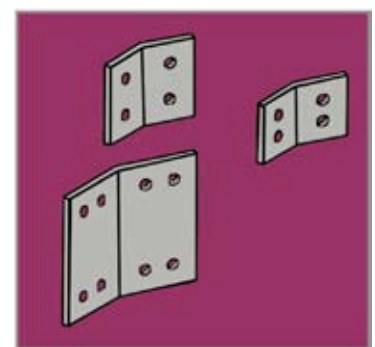

30° Horizontal Splice Plate

Catalog #

- XSS-8306H*
- XSS-4304H*
- XSS-4304H*

Hardware suffix is needed to complete the part number.
All splice plate hardware is 3/8"
Furnished in pairs.

Hardware suffixes:
SS6 = 316SS
MO = Monel
SB = Silicon Bronze
FR = Husky Fiberglass

FIBERGLASS

Accessories

Vertical Adjustable Splice Plates

These plates provide for changes in elevation that do not conform to standard vertical fittings.

- ◆ Furnished in pairs
- * Hardware suffix needed to complete part number

	Height	Catalog No.
Stainless	6"	XSS-8026*
Steel	4"	XSS-4024*
	3"	XSS-4023*

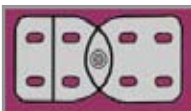

Horizontal Adjustable Splice Plates

These plates provide for changes in the horizontal direction that do not conform to standard fittings.

- ◆ Furnished in pairs
- * Hardware suffix needed to complete part number

	Height	Catalog No.
Stainless	6"	XSS-8036*
Steel	4"	XSS-4034*
	3"	XSS-4033*

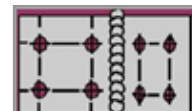

Step Down Plates

These splice plates provide for changes in side tail heights.

- ◆ Furnished in pairs
- * Hardware suffix needed to complete part number

	Height	Catalog No.
Stainless	6" to 3"	XSS-8063*
Steel	6" to 4"	XSS-8064*
	4" to 3"	XSS-4043*



Tray to Box Splice Plates

These plates are used to attach the end of a tray run to a distribution box or control center.

- ◆ Furnished in pairs
- ◆ Not available in stainless steel
- * Hardware suffix needed to complete part number

	Height	Catalog No.
FRP	6"	XFP-8056*
	4"	XFP-4054*
	3"	XFP-4053*



Vertical Splice Plates

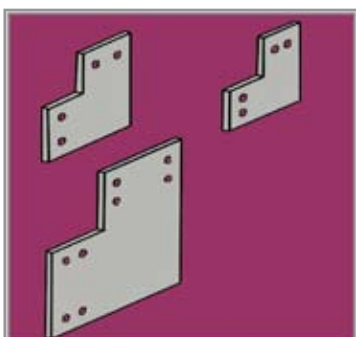

90° Vertical Splice Plate
Catalog #
XSS-8906V*
XSS-4904V*
XSS-4903V*

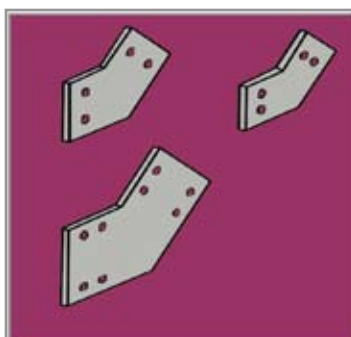

45° Horizontal Splice Plate
Catalog #
XSS-8456V*
XSS-4454V*
XSS-4453V*

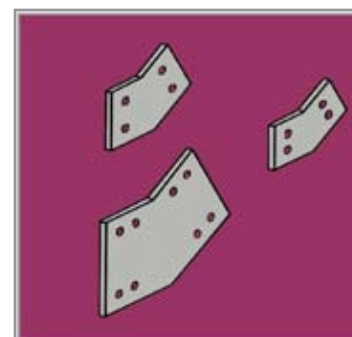

30° Horizontal Splice Plate
Catalog #
XSS-8306V*
XSS-4304V*
XSS-4303V*

FIBERGLASS

Ladder Drop Out

Specially designed Ladder Drop-Outs provide a rounded surface with adequate radius to protect cable as it exits from the tray, preventing damage to insulation. (4" radius)

Catalog #XF-1104-W

(W = width)

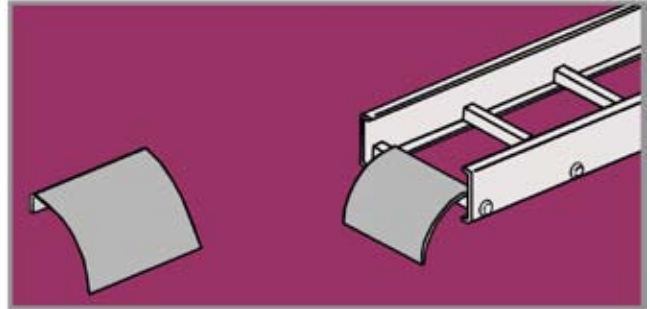

Clamp/Guide—Husky Fiberglass

Designed for use with 3/8" hardware (not included). Combination hold down clamp and guide. This item is sold in pairs.

Catalog #XF-1208 (non-metallic)

Clamp/Guide—Stainless Steel
For use with 1/2" hardware (not included).

Catalog #XSS-1205 (SS6)

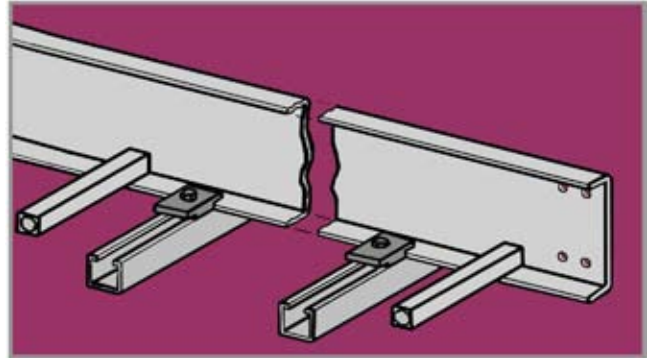

Flexible Horizontal Barrier Kit

One kit allows up to 38" radius position of the barrier. For larger than 38" radius, two kits are required.

Catalog Number	Side Rail Height	Loading Depth 'H'
BS06P-90HBFL	6"	4-11/16"
BS04P-90HBFL	4"	2-11/16"
BS03P-90HBFL	3"	1-3/4"

For Vinylester—replace "P" with V".

Kit Contents—1pc. Of 72" straight barrier, 4 barrier strip clips, 8 thermo plastic drive rivets, 4 stainless steel self drilling screws.
Assembly required—directions are included.

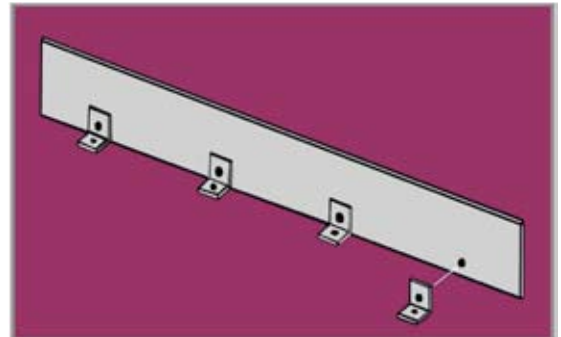

Vertical Barriers

Sample Catalog #BS06-P-90VO-24

BS06 = Barrier Size
P = Material
90 = Angle
VO = Vertical Inside or Vertical Outside
24 = Radius

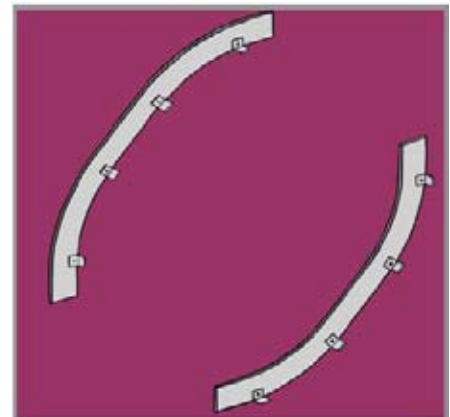

FIBERGLASS

Resin Seal Kit and Spray Sealant

Brush-On Resin Seal Kit is used to reseal Husky Fiberglass after field modifications.

Catalog #8-2-SEAL (1 pint)

Catalog #8-2-Seal-QT (1 quart)

Contents: Resin, Catalyst, Stir Stick, and Applicator. All kits are Vinylester Resin.

Spray Sealant is also used to reseal Husky Fiberglass after field modifications.

Catalog #Clear-1215

12 fl. oz. spray acrylic



Thermo Plastic Drive Rivet

Shipped in packages of 25 pcs.

Catalog #TPDR



Cover

1/8" Thick, 120" Long

10 ea. #10 stainless, self-drilling screws are provided with each section.

Catalog #	Description
FC-P-W*-120	Flat Polyester
FC-V-W*-120	Flat Vinylester
PC-P-W*120	Peaked Polyester
PC-V-W*-120	Peaked Vinylester

Peaked covers are for straight sections only.

W* = insert width of tray.

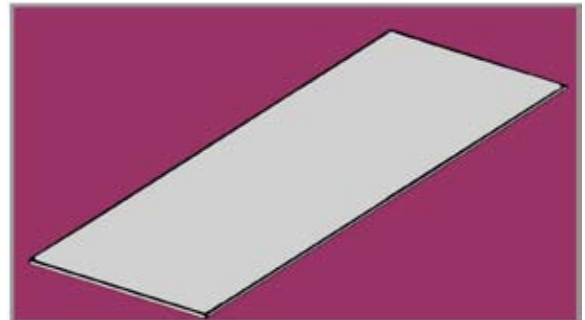

Cover Clamps

Standard Cover Clamp

Catalog #	Side Rail Height
XCC-P-9016	6"
XCC-P-9014	4"
XCC-P-9013	3"

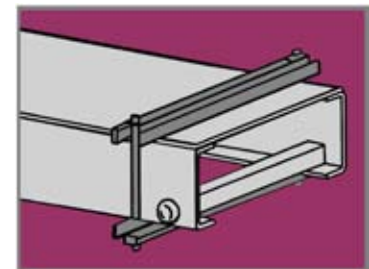
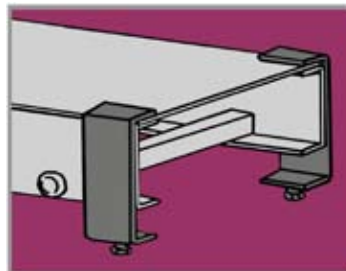

Heavy Duty Cover Clamp

Catalog #	Side Rail Height
XWC-P-W*-9064	6"
XWC-P-W*-9044	4"
XWC-P-W*-9034	3"

For Vinylester, replace "P" with "V" in the catalog number.

W* = tray width

FIBERGLASS

Loading Information—Beam Loads: The charts below list the total allowable uniform load for various simple spans based on a minimum safety factor of 2. If the load is concentrated at the center span, multiply the load from the below charts by 0.5 and the corresponding deflection by 0.8. Note: All beam should be supported in a manner to prevent rotation at supports. Long, deep beams should be tied between supports to prevent twist.

Beam Loading Data for Glass Reinforced Polyester Resin

		Maximum Allow. Load		Defl. @ Maximum Allow. Beam Load		Allowable Load @ Deflection			
						1/240 Span		1/360 Span	
Beam Span	Part Number	lbs.	N	in.	mm	lbs.	N	lbs.	N
12" (305)	SSP-100	793	3527	0.106	2.69	373	1659	249	1107
	SSP-100-D	2301	10235	0.060	1.52	1928	8576	1285	5715
	SSP-158	1783	7931	0.067	1.70	1327	5902	885	3936
	SSP-158-D	5172	23005	0.037	.94	5172	23005	4696	20888
24" (609)	SSPP-100	397	1766	0.425	10.79	93	413	62	276
	SSPP-100-D	1150	5115	0.239	6.07	482	2144	321	1428
	SSPP-158	891	3963	0.269	6.83	332	1477	221	983
	SSPP-158-D	2586	11502	0.147	3.73	1761	7833	1174	5222
36" (914)	SSP-100	264	1174	0.957	24.31	41	182	28	124
	SSP-100-D	767	3411	0.537	13.64	214	952	143	636
	SSP-158	594	2642	0.604	15.34	147	654	98	436
	SSP-158-D	1724	7668	0.330	8.38	783	3483	522	2322

Beam Loading Data for Glass Reinforced Vinylester Resin

		Maximum Allow. Load		Defl. @ Maximum Allow. Beam Load		Allowable Load @ Deflection			
						1/240 Span		1/360 Span	
Beam Span	Part Number	lbs.	N	in.	mm	lbs.	N	lbs.	N
12" (304)	SSV-100	988	4394	0.112	2.84	441	1961	294	1308
	SSV-100-D	2866	12748	0.063	1.60	2279	10137	1519	6756
	SSV-158	2221	9879	0.071	1.80	1569	6979	1046	4652
	SSV-158-D	6443	28658	0.039	.99	6443	28658	5550	24686
24" (609)	SSV-100	494	2197	0.448	11.38	110	489	73	325
	SSV-100-D	1433	6374	0.252	6.40	570	2535	380	1690
	SSV-158	1110	4937	0.283	7.19	392	1743	261	1161
	SSV-158-D	3221	14327	0.155	3.94	2081	9256	1387	6169
36" (914)	SSV-100	329	1463	1.009	25.63	49	218	33	147
	SSV-100-D	955	4248	0.566	14.37	253	1125	169	752
	SSV-158	740	3291	0.637	16.18	174	774	116	516
	SSV-158-D	2148	9554	0.348	8.84	925	4114	617	2744

Recommended Guideline:

Published design loads are based on usage @ 70°F(21°C) and must be reduced for continuous exposure to higher temperatures. Refer to the chart at right for high temperature applications.

Temperature	Design Load Multiplier
75°F (24°C)	100%
75°F (24°C)	90%
75°F (24°C)	78%
75°F (24°C)	68%
75°F (24°C)	60%
75°F (24°C)	52%

FIBERGLASS

Channels, Combinations and Hole Patterns

Part #	Material/Resin	Description	Color	Wt lbs./ft.	Wt kg/ft.
SSP-100	Polyester	Solid Back	Gray	.47	.70
SSV-100	Vinylester	Solid Back	Beige	.47	.70
SSP-100-D	Polyester	Solid Back	Gray	.86	1.28
SSV-100-D	Vinylester	Solid Back	Beige	.86	1.28

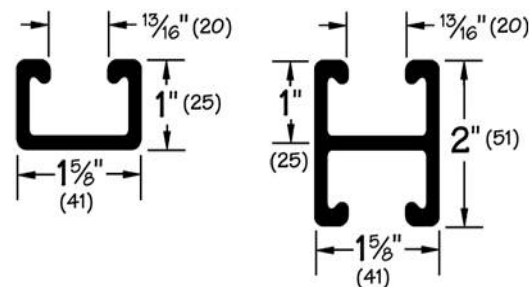

Part #	Material/Resin	Description	Color	Wt lbs./ft.	Wt kg/ft.
SSP-158	Polyester	Solid Back	Gray	.63	.94
SSV-158	Vinylester	Solid Back	Beige	.63	.94
SSP-158-D	Polyester	Solid Back	Gray	1.17	1.75
SSV-158-D	Vinylester	Solid Back	Beige	1.17	1.75

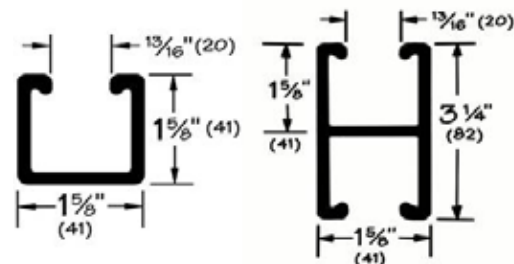

Part #	Material/Resin	Description	Color	Wt lbs./ft.	Wt kg/ft.
SSP-100-H	Polyester	Holes in Back	Gray	.45	.67
SSV-100-H	Vinylester	Holes in Back	Beige	.45	.67
SSP-158-H	Polyester	Holes in Back	Gray	.61	.91
SSV-158-H	Vinylester	Holes in Back	Beige	.61	.91

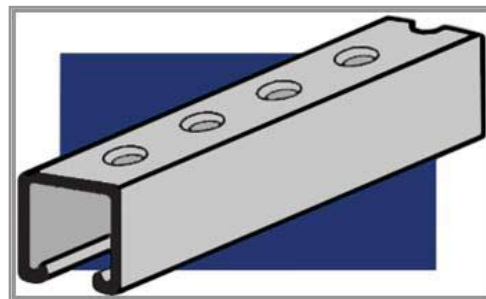

Part #	Material/Resin	Description	Color	Wt lbs./ft.	Wt kg/ft.
SSP-100-S	Polyester	Slots in Back	Gray	.46	.69
SSV-100-S	Vinylester	Slots in Back	Beige	.46	.69
SSP-158-S	Polyester	Slots in Back	Gray	.62	.93
SSV-158-S	Vinylester	Slots in Back	Beige	.62	.93

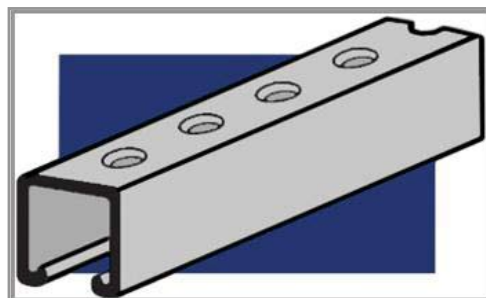

Part #	Material/Resin	Description	Color	Wt lbs./ft.	Wt kg/ft.
SSP-158-I	Polyester	Conc. Insert	Gray	1.04	1.55
SSV-158-I	Vinylester	Conc. Insert	Beige	1.04	1.55

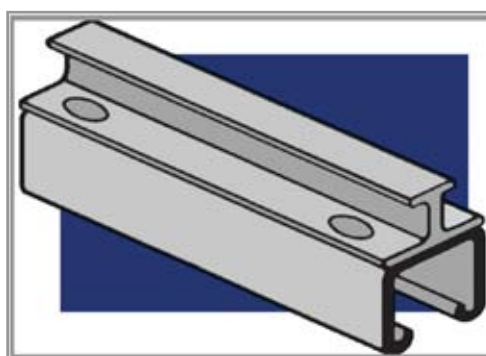

FIBERGLASS

Hex Head Bolt

Part #	Thread Size	Design lbs.	Load N	Max in-lbs	Torque N-m	Weight / lbs.	C g
F516100 5/16x1	5/16"-18	190	845	30	3.4	.4	181
F516114 5/16x-1/4	5/16"-18	190	845	30	3.4	.4	181
F38100 3/8x1	3/8"-16	300	1334	45	5.1	.9	408
F38114 3/8x1-1/4	3/8"-16	300	1334	45	5.1	1.1	499
F38212 3/8x2-1/2	3/8"-16	300	1334	45	5.1	1.5	680
F12100 1/2x1	1/2"-13	490	2180	110	12.4	1.4	635
F12114 1/2x1-1/4	1/2"-13	490	2180	110	12.4	1.8	816

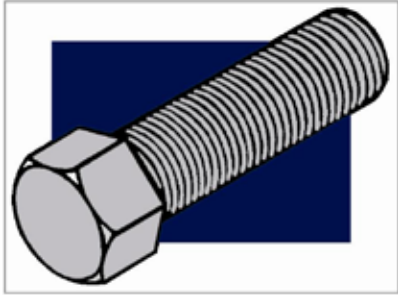

All-Thread Rod

Part #	Thread Size	Design lbs.	Load N	Max in-lbs	Torque N-m	Weight / lbs.	C g
F38AT	3/8"-16	425	1890	45	5.1	.08	36
F12AT	1/2"-13	750	3336	110	12.4	.13	59
F58AT	5/8"-11	950	4226	230	26.0	.21	95

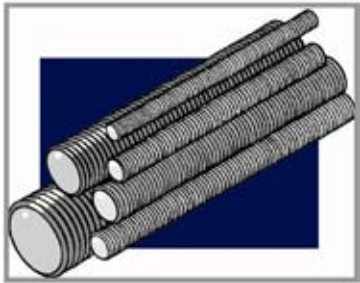

Hex Nut

Part #	Thread Size	H in.	mm	Weight / lbs.	C g
F38HN	3/8"-16	21/64	8	.3	136
F12HN	1/2"-13	7/16	11	.7	318
F58HN	5/8"-11	35/64	14	1.4	635

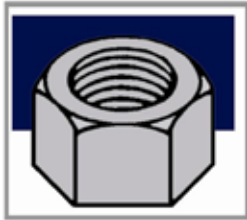

All-Thread Rod Hex Nut

Part #	Thread Size	H in.	mm	Weight / lbs.	C g
F38ATHN	3/8"-16	3/4	19	.8	376
F12ATHN	1/2"-13	7/8	22	1.7	771



Rod Coupler

Part #	Thread Size	Weight / lbs.	C g
FRC38	3/8"-16	7.4	3357
FRC12	1/2"-13	11.3	5118
FRC58	5/8"-11	16.7	7575



Other sizes are available, please consult factory for details.

FIBERGLASS

U-Bolt

Part #	Nominal in.	Pipe Size mm	Design lbs.	Load A in.	Design lbs.	Load B in.	Max in-lbs.	Torque N-m	Wt/lbs.	c g
FUB050	1/2	15	300	1334	150	667	30	3.4	3.5	1588
FUB075	3/4	20	300	1334	150	667	30	3.4	3.9	1769
FUB100	1	25	300	1334	150	667	30	3.4	4.4	1996
FUB114	1-1/4	32	300	1334	150	667	30	3.4	4.8	2177
FUB112	1-1/2	40	300	1334	150	667	30	3.4	5.2	2359
FUB200	2	50	600	2669	200	890	60	6.8	7.7	3493
FUB212	2-1/2	65	600	2669	200	890	60	6.8	10.2	4627
FUB300	3	80	600	2669	200	890	60	6.8	12.6	5715
FUB312	3-1/2	90	600	2669	200	890	60	6.8	15.1	6849
FUB400	4	100	600	2669	200	890	60	6.8	17.6	7983

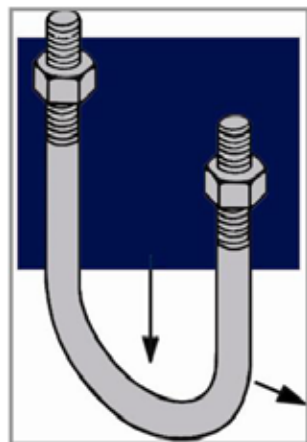

Channel Nuts & Washers

Part #	Part # w/Spring	Thread	Pull-lbs.	Out N	Slip lbs.	Resist. N	Max. in-lbs	Torque N-m	Wt/lbs.	C g
FCN38	FCN38WO	3/8-16	300	1334	150	667	200	22.6	2.3	1043
FCN12	FCN12WO	1/2-13	300	1334	150	667	200	22.6	2.3	1043



Flat Washer

Part #	Hole Size	Weight lbs.	C g
F38W	3/8"	.5	227
F12W	1/2"	.5	227
F58W	5/8"	.5	227
F34W	3/4"	.5	227
F100W	1"	.5	227

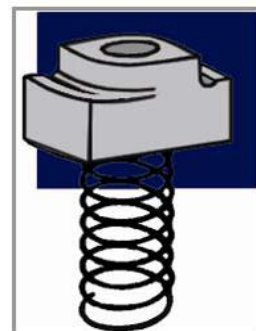

Resin Seal Kit and Spray Sealant

Brush-On Resin Seal Kit is used to reseal Husky Fiberglass after field modifications.

Catalog #8-2-SEAL (1 pint)

Catalog #8-2-Seal-QT (1 quart)

Contents: Resin, Catalyst, Stir Stick, and Applicator. All kits are Vinylester Resin.

Spray Sealant is also used to reseal Husky Fiberglass after field modifications.

Catalog #Clear-1215

12 fl. oz. spray acrylic



Adjustable Pipe Clamp

Part #	Nominal in.	Pipe Size mm	Pipe lbs.	O.D. Range mm	Design lbs.	Load N	Max. in-lbs	Torque N-m
SAPC050	1/2 to 3/4	15,20	75-1.05	19-28	75	.33	15	1.69
SAPC100	1-1 to 1/2	25,40	1.05-1.90	29-48	150	.67	22	2.48
SAPC112	1-1/2 to 2-1/2	40,65	1.90-2.87	48-73	150	.67	22	2.48
SAPC212	2-1/2 to 3-1/2	65,90	2.87-4.0	73-101	150	.67	22	2.48

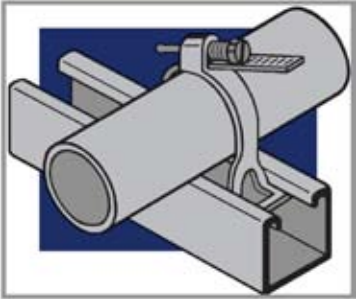

Safety factor of 3 on Design Load. Not recommended for vertical installation without additional supports.

Rigid Pipe Clamp

Part #	Nominal in.	Pipe Size mm	Design lbs.	Load N	Max. in-lbs	Torque N-m
SRPC050	1/2	15	300	1.33	10	1.13
SRPC075	3/4	20	300	1.33	10	1.13
SRPC100	1	25	300	1.33	10	1.13
SRPC114	1-1/4	32	300	1.33	10	1.13
SRPC112	1-1/2	40	300	1.33	10	1.13
SRPC200	2	50	300	1.33	10	1.13
SRPC212	2-1/2	65	300	1.33	10	1.13
SRPC300	3	80	300	1.33	10	1.13
SRPC312	3-1/2	90	300	1.33	10	1.13
SRPC400	4	100	300	1.33	10	1.13

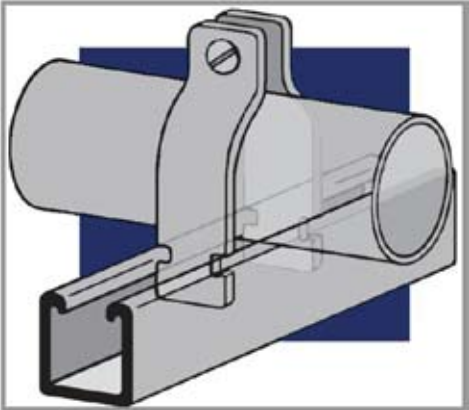

Safety factor of 3 on Design Load. Not recommended for vertical installation without additional supports.

Conduit Swivel Clamp

Cable Tray Designation (CTD) Required.
 Example: 6CP, 4P
 Pipe clamps are a separate order item.

Catalog #SCSC-(CTD)

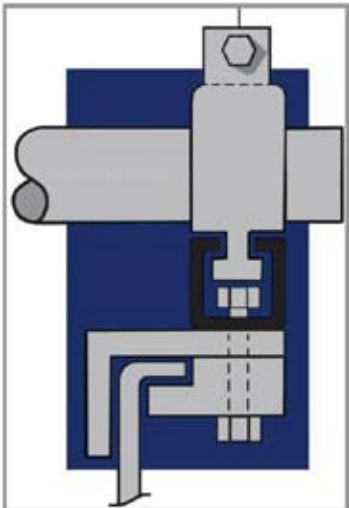

FIBERGLASS

Clevis Hangers

Part #	Nominal in.	Pipe Size mm	Max. Pipe lbs.	O.D. Range mm	Design lbs.	Load N	Hanger Rod Size
SCH200	2	50	2-1/2	63	90	.40	1/2"-13
SCH212	2-1/2	65	3-1/4	82	120	.54	1/2"-13
SCH300	3	80	3-7/8	98	160	.71	1/2"-13
SCH400	4	100	5	127	250	1.12	5/8"-11
SCH600	6	150	7	177	400	1.79	5/8"-11
SCH800	8	200	9	228	450	2.01	5/8"-11
SCH1000	10	250	11-3/8	289	500	2.24	5/8"-11
SCH1200	12	300	13-1/2	342	600	2.69	5/8"-11

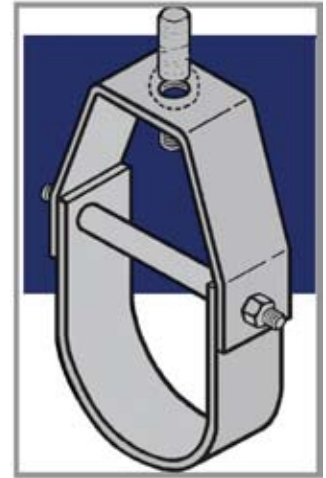

Safety Factor of 3 on Design Loads @120°F (49°C). Insulation may be required at high temperatures. Note: Order hanger rods and nuts separately.

Support Brackets

Part #	Dimension in.	A mm	Design lbs.	Load N
SB1-06P	10	250	1400	6.22
SB1-09P	13	330	1000	4.45
SB1-12P	16	406	800	3.56
SB1-18P	22	559	675	3.00
SB1-24P	28	711	450	2.00
SB2-30P	34	863	750	3.33
SB2-36P	40	1016	750	3.33
SB2-24P	28	711	750	3.33

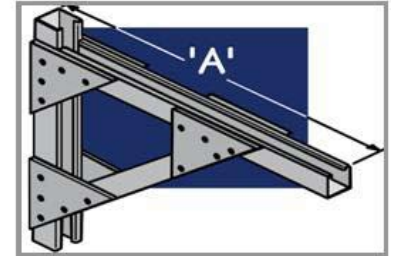
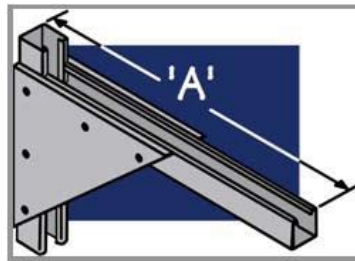

Beam Clamp

Part #	Description	Design lbs.	Load N
SBC	Beam Clamp	800	3.56
SBC-RC	Beam Clamp w/clip	800	3.56

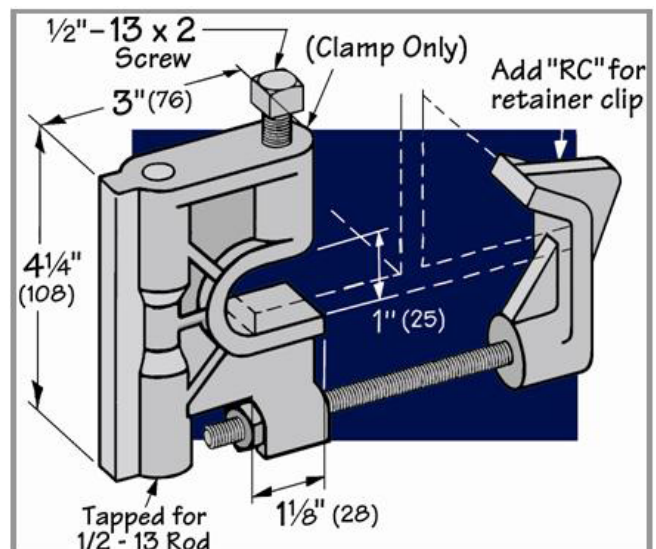

Fittings

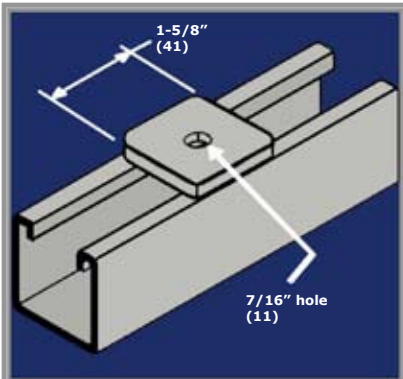

Catalog #SFP-1S7
FRP Polyester (1) 7/16" hole strut fitting.

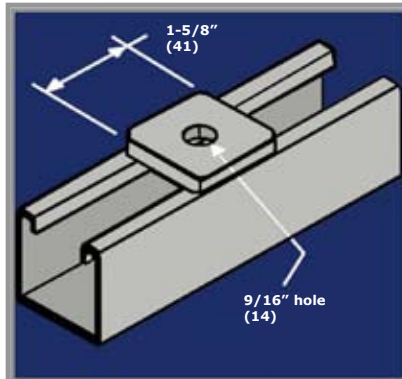

Catalog #SFP-1S9
FRP Polyester (1) 9/16" hole strut fitting.

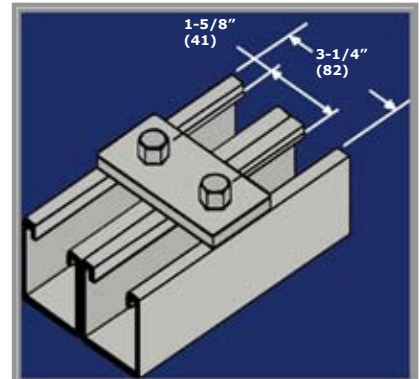

Catalog #SFP-2S
FRP Polyester (2) hole straight strut fitting.

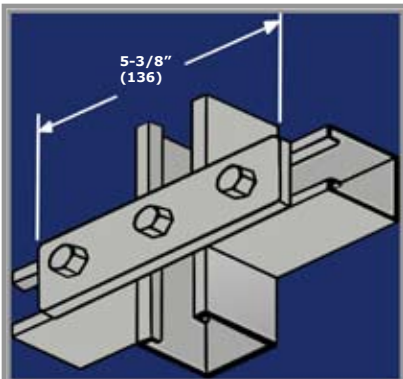

Catalog #SFP-3S
FRP Polyester (3) hole straight strut fitting.

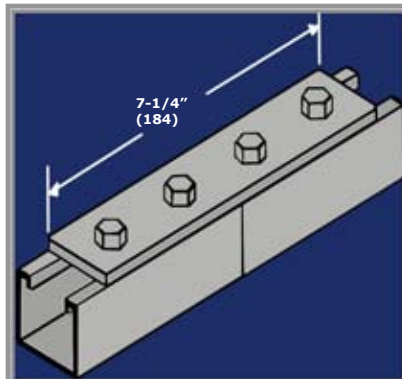

Catalog #SFP-4S
FRP Polyester (4) hole straight strut fitting.

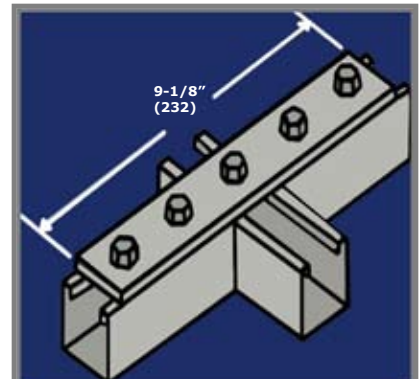

Catalog #SFP-5S
FRP Polyester (5) hole straight strut fitting.

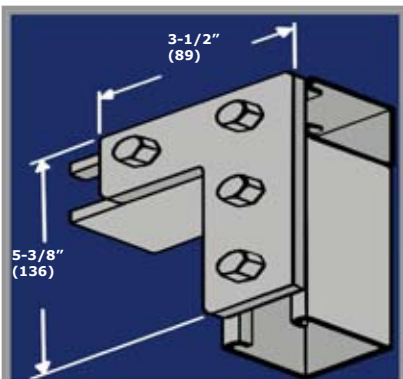

Catalog #SFP-4HL
FRP Polyester (4) hole horizontal 90 degree strut fitting.

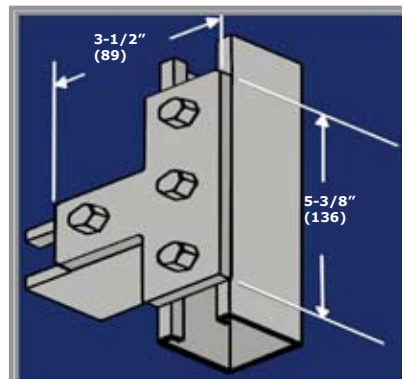

Catalog #SFP-4HT
FRP Polyester (4) hole horizontal tee strut fitting.

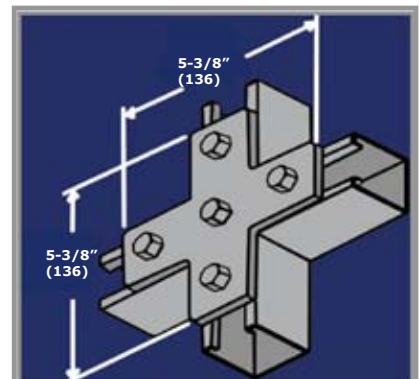

Catalog #SFP-5HX
FRP Polyester (5) hole horizontal cross strut fitting.

FIBERGLASS

Fittings

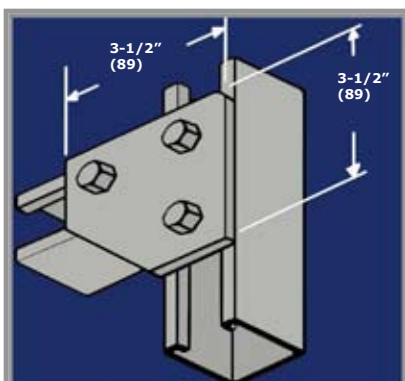

Catalog #SFP-3HCG
FRP Polyester (3) hole horizontal corner gusset strut fitting.

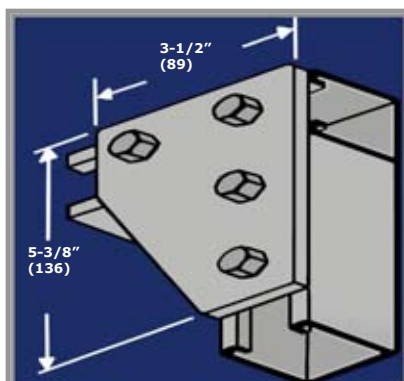

Catalog #SFP-4HCG
FRP Polyester (4) hole horizontal corner gusset strut fitting.

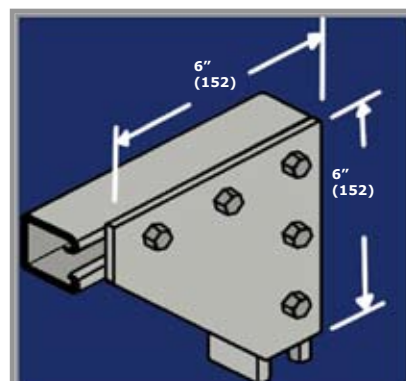

Catalog #SFP-5HCG
FRP Polyester (5) hole horizontal corner gusset strut fitting.

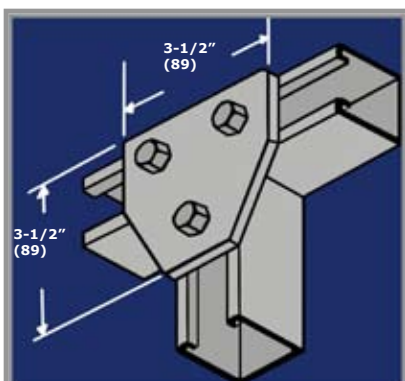

Catalog #SFP-3HTG
FRP Polyester (3) hole horizontal tee gusset strut fitting.

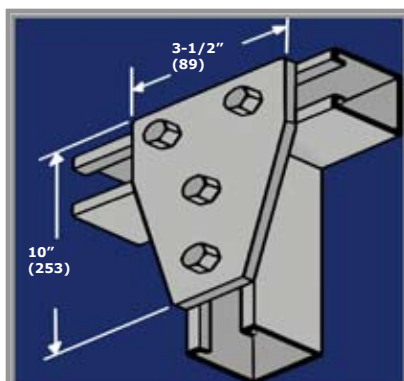

Catalog #SFP-4HTG
FRP Polyester (4) hole horizontal tee gusset strut fitting.

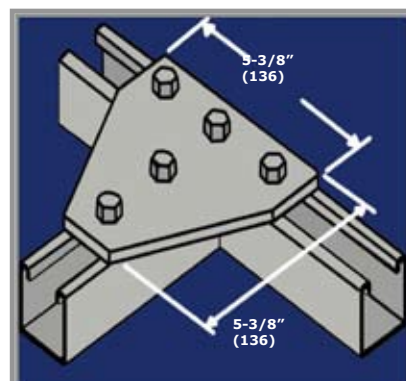

Catalog #SFP-5HTG
FRP Polyester (5) hole horizontal tee gusset strut fitting.

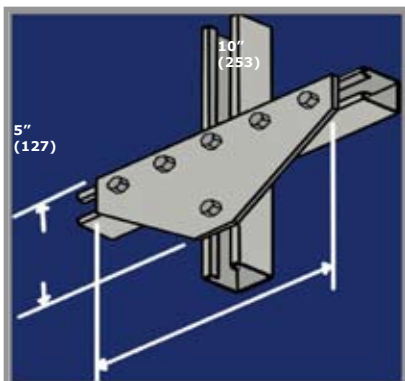

Catalog #SFP-6HTG
FRP Polyester (6) hole horizontal tee gusset strut fitting.

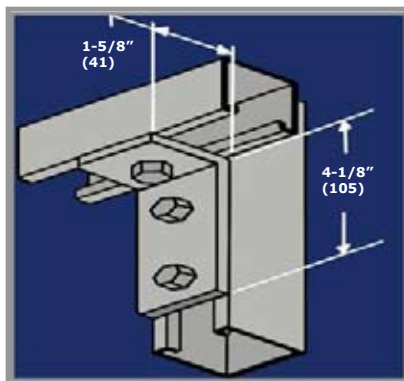

Catalog #SFP-3VL
FRP Polyester (3) hole vertical 90° strut fitting.

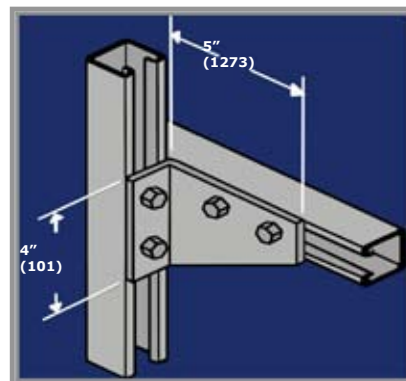

Catalog #SFP-4VGL
FRP Polyester (4) hole vertical 90° gusset left strut fitting.

FIBERGLASS

Fittings

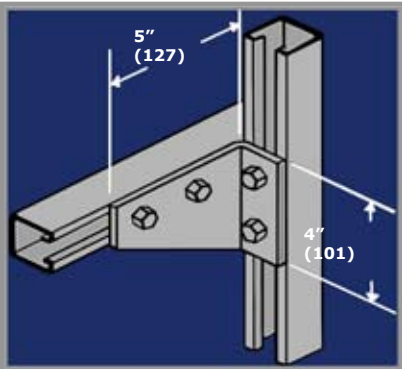

Catalog #SFP-4VGR
FRP Polyester (4) hole vertical 90° gusset right strut fitting.

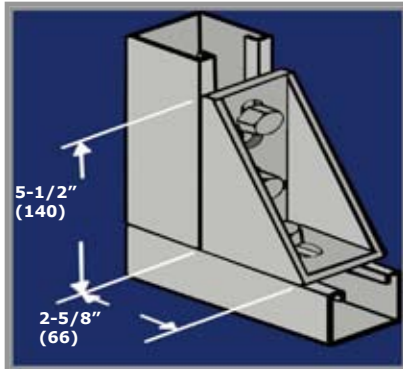

Catalog #SFP-3CB
FRP Polyester (3) hole corner bracket strut fitting.

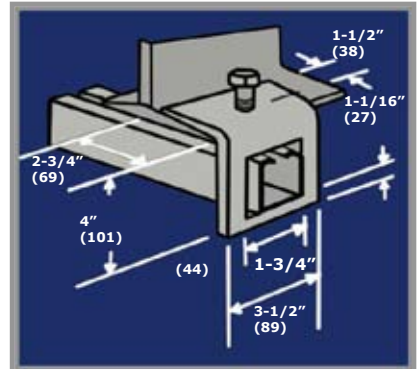

Catalog #SWC-158
FRP Polyester 1-5/8" Window Clamp

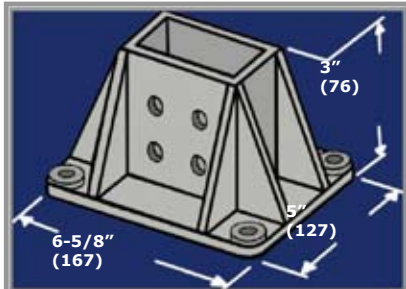

Catalog #SSV-DBASE
FRP Polyester Double Strut vertical support base.

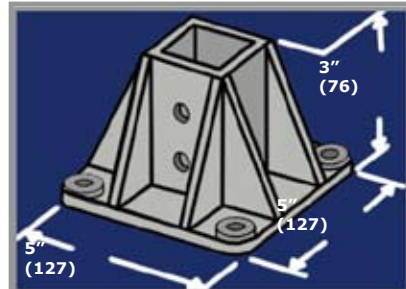

Catalog #SSV-SBASE
FRP Polyester Single Strut vertical support base.

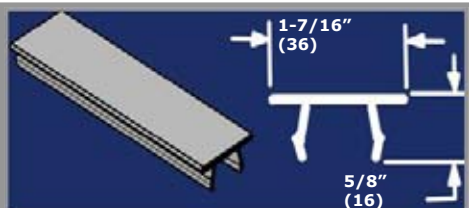

Catalog #SSCS-158
Closure Strip

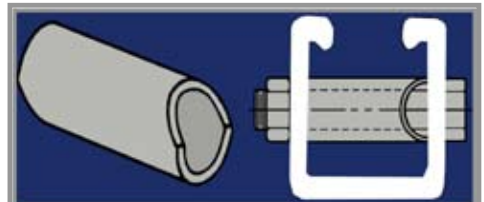

Catalog #SCSP-158
Channel Spacer (for 3/8" rod).

FIBERGLASS

Other fittings are available, please consult factory for details.